

SPINchiller² Duct

HIGH EFFICIENCY AIR-COOLED LIQUID CHILLER
FOR INDOOR INSTALLATION

WSA-XSC2 432-120D SERIES

Nominal cooling capacity from 115 kW to 313 kW



The WSA-XSC2 liquid chillers are units for indoor installation with air ducted condensation.

A-CLASS OF ENERGY EFFICIENCY:

modular Scroll technology, plate evaporators at heat exchange high efficiency, electronic expansion valves, ECOBREEZE plug fans with permanent magnet motors

ESEER SEASONAL EFFICIENCY AT THE TOP OF ITS CLASS:

significantly reduced operating costs over the entire annual cycle, that can be further improved with the DST control logic (Dynamic Supply Temperature) which maintains a constant system return temperature, activable by the user

GREAT COMPACTNESS AND ACCESSIBILITY:

easy installation and maintenance even in shafts with restricted spaces

HIGH AVAILABLE STATIC PRESSURE:

plug fans ECOBREEZE, high-performance and variable speeds that adapt to the system and ensure the proper expulsion of air through particularly complex channels

VERSATILITY OF USE:

the different options available for the supply and return air flow allow you to easily connect the unit to the air channels

Table of contents

| | |
|--|----|
| Total comfort is required all year round, even in the most difficult application situations..... | 4 |
| High energy efficiency within the annual cycle..... | 6 |
| Reliability and saving throughout the entire life-cycle | 10 |
| Efficient use of energy with heat recovery..... | 13 |
| Standard unit technical specifications | 14 |
| General technical data..... | 17 |
| Electrical data | 18 |
| Operating range | 18 |
| Performances in cooling..... | 19 |
| Electric fan performance | 20 |
| Correction factors for glycol use | 21 |
| Fouling Correction Factors..... | 21 |
| Internal exchanger pressure drops | 21 |
| Admissible water flow rates..... | 22 |
| Exchanger operating range | 22 |
| Overload and control device calibrations | 22 |
| Sound levels | 22 |
| Configurations..... | 23 |
| Accessories - Hydronic assembly..... | 26 |
| HydroPack..... | 29 |
| Accessories | 31 |
| Accessories separately supplied | 35 |
| Option compatibility - WSA-XSC2 series..... | 36 |
| Dimensional drawings..... | 37 |

Total comfort is required all year round, even in the most difficult application situations

Easy to position in the available shafts

The unit can be positioned easily in one of the following settings:

- in shafts;
- in service rooms, for instance, warehouses and store rooms;
- directly in the served area, in a visible position.

Versatility is ensured by the two solutions available for the air exhaust from the source side heat exchanger.

- The first solution is the installation in the shaft or in the service room, with rear intake and vertical ducted outlet.
- The second is the installation in a shaft or service room or in the environment, with intake and ducted outlet both from the rear.

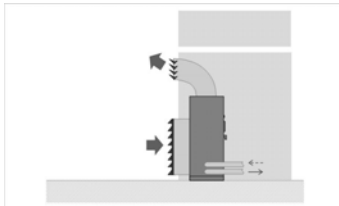

REAR INTAKE AND DUCTED VERTICAL EXHAUST

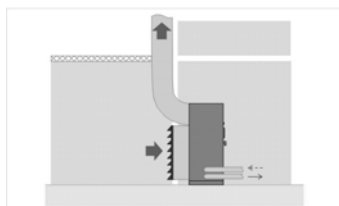

REAR INTAKE AND DUCTED REAR EXHAUST



EXAMPLE OF EXTERNAL AIR EXHAUST GRILLE

This image represents only a few of positioning possibilities

Fans at variable speed for minimal noise emission

All units are supplied complete with electronic pressure control of the external exchanger. It automatically reduces the fan speed when the heat load is reduced.

Since the fans are the unit's main noise source, the benefits are evident especially during the night hours, when the load is reduced but sensitivity to noise is enhanced.

All this translates into a reduction of sound pressure down to 8 dB(A) compared to full load operation in 90% of operating time of the unit.

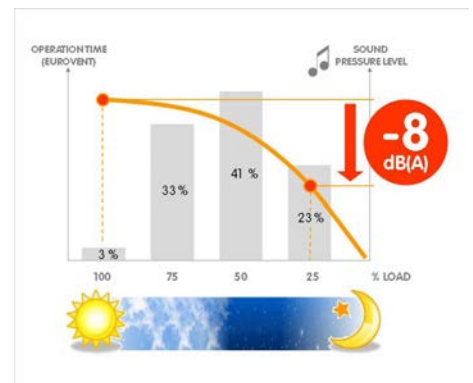

Operating completely automatic

The microprocessor control automatically manages operation according to the maximum efficiency criterion and includes many safety and alarm management functions.

The interface terminal has a backlit graphic display and a multifunction access keypad. The multilevel menu is protected by different passwords according to the type of user. The daily / weekly timer comes as standard.



Efficient precision

The sequential activation logics compressors allow:

- accurately following the load heating/cooling, supplying better comfort;
- reducing the number of compressor start-ups which is the main cause for wear and tear
- increasing the life cycle of the unit
- reducing time and costs for any repairs, thanks to the modularity of components, their reduced dimensions and the lower cost compared to semi-hermetic compressors.

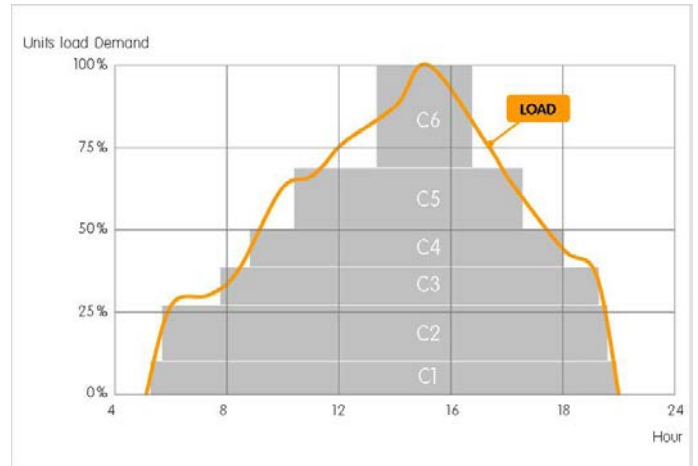

Load cover of the double-circuit units with 6 capacity steps

Produces hot water freely

Condensation heat recovery:

- Partial: it recovers about the 20% of the available heat (desuperheater)
- Total: it recovers the 100% of the available heat

It allows the free DHW production for:

- Hot water coil supply for reheat
- Domestic hot water production (with intermediate exchanger)
- Other processes or operations

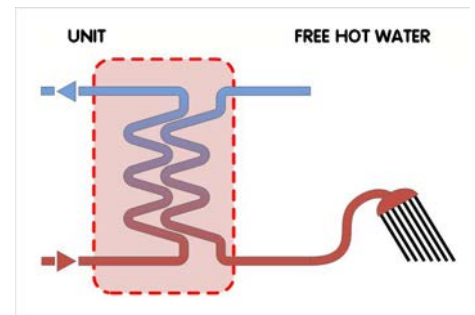

Even for low water temperature

The unit is also perfectly adapted for use in process cooling where the low temperature version (Brine) together with the addition of glycol to the thermo-vector liquid produces chilled water down to -7°C .



High energy efficiency within the annual cycle

Increases the building value

The unit is characterized by its high EER efficiency in cooling at full load, which exceeds the value of 2.7 and places it in the A-class of Eurovent energy efficiency.

The high efficiency reduces the complex primary energy requirements and the CO2 emissions compared to traditional solutions. It follows the improvement of the energy class of the building and therefore its value on the property market.

It is often possible to access the foreseen benefits to promote the use of the unit at low consumption.

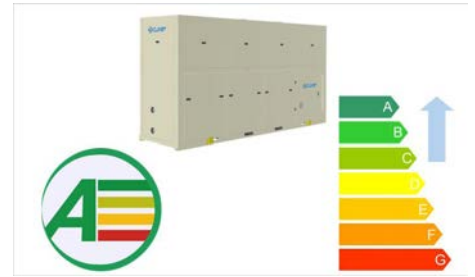

Maximum efficiency is necessary with a part load

The system is required to generate maximum power only for a short amount of time. Therefore, it is essential to have the maximum efficiency under part load condition. This is the only way to actually reduce overall yearly consumptions.

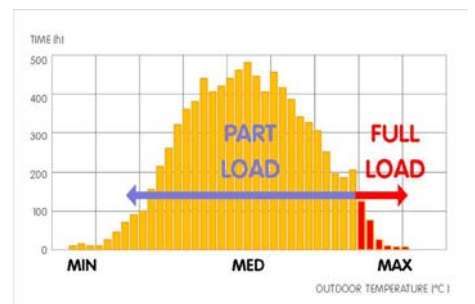

Part load efficiency determines the seasonal efficiency

Seasonal efficiency is conventionally represented by ESEER parameters according to Eurovent and IPLV parameters according to ARI. Both give great importance to part load operation, since it is the predominant condition.

| SYSTEM LOAD | WEIGHT (ESEER) * | WEIGHT (IPLV) * |
|-------------|------------------|-----------------|
| 100% | 3% | 1% |
| 75% | 33% | 42% |
| 50% | 41% | 45% |
| 25% | 23% | 12% |

EUROVENT (ESEER) supply times reference and ARI (IPLV) reference for seasonal efficiency calculations.

Modular Scroll technology boosts performance at part load

Since the maximum capacity is requested only for short periods of time, it is fundamental to place the maximum efficiency in the part load conditions. The unit uses high efficiency Scroll compressors. The advantages are:

- compressors manufactured in large ranges, with strict quality controls and maximum reliability thanks to the high production volumes
- each refrigerant circuit employs two Scroll compressors, almost always of different sizes in order to obtain more adjustment steps. This way, only the necessary energy is supplied.



THE SEQUENTIAL DEACTIVATION OF THE COMPRESSORS INCREASES EFFICIENCY

Doubled efficiency

The heat exchange surface is sized for full capacity operation. Under part load condition, some compressors are automatically deactivated. Under this condition, in fact, the compressors in operation make use of a much larger surface.

This entails a reduced condensation temperature and an increased evaporation temperature. This way, the compressor capacity consumption is reduced with respect to the yield thereby increasing the overall efficiency of the unit.

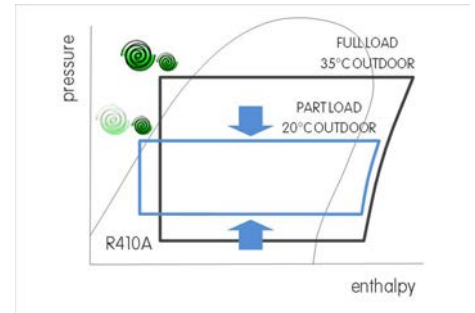

It further increases the seasonal energy efficiency

The unit is standard equipped with DST (Dynamic Supply Temperature) logic control, activable by the user.

Unlike the traditional control logic that aims at maintaining the water supply temperature constant, the DST logic aims at keeping constant the water return temperature, modifying the supply temperature dynamically according to the load. In cooling at part load the evaporation temperature raises and therefore furtherly increases the seasonal energy efficiency.

The DST control allows a considerable consumption and operation costs reduction, especially in civil applications, upon verification of the air treatment system's dehumidification capacity during cooling at part load.

The DST control is particularly interesting when combined with active thermodynamic fresh air systems which, thanks to their direct expansion circuit, allow them to operate the outdoor air treatment independently and autonomously. The water chiller can thus vary the system water supply temperature, thereby optimising energy efficiency in the yearly cycle.

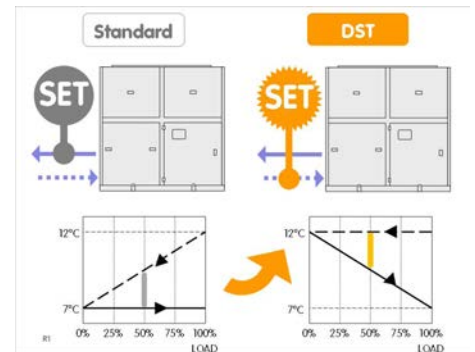

Stable and reliable operating

The numerous technical solutions used in the refrigeration and hydraulic circuit as well as enabling very high levels of overall efficiency to be reached, also guarantee that the correct unit operating.

- The anti-freeze sensor on the outlet water in addition to the device which monitors the water flow work together to maintain unit safety and combat the risk of freezing.
- The electronic expansion valve (EEV) adapts quickly and precisely to the actual load required for use, thereby allowing for a more stable and accurate control compared to the mechanical thermostatic valves (TEV). All this results in further efficiency and greater compressor durability.
- Furthermore, continuous adaptation to load conditions takes place without swings in the refrigeration circuit with the advantage of increasing the efficiency and the operating life of the compressor.

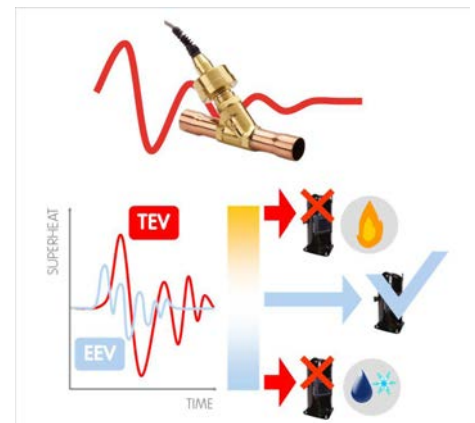

THE ELECTRONIC EXPANSION VALVE MAKES THE REFRIGERATION CIRCUIT HIGHLY STABLE AND EFFICIENT

High efficient refrigerant

R410A is the mix of two refrigerants used in equal parts: R32 that supplies the heating capacity and R125 that controls the flammability. It is a chlorine free refrigerant (HFC) with numerous advantages:

- ODP (Ozone Depletion Potential) = 0
- High volumetric effect thanks to the high coefficient global thermal exchange and to the pressure variation (glide) which is almost nil during the evaporation phase
- Elevated density and efficiency, with greater compactness of the refrigeration circuit and therefore the responsible use of materials and small refrigerant quantity, for a reduced environmental impact.



Very high heat exchange efficiency

Thanks to the heat exchangers with large front surface and reduced depth, we obtain:

- improved operating temperature of the refrigeration circuit and hence improved efficiency, since this reduces the difference between the air temperature and the refrigerant fluid temperature inside the exchanger;
- fan consumption reduction, thanks to the lower depth of the exchanger which reduces pressure drop in the air flow. The automatic fan speed control, standard supplied, minimises moreover the air flow required for the correct operation and thus further reduces the consumptions;
- sound level reduction, since larger surface areas allow lower air speeds on the exchangers.



Versatility of reversed blades rotor

This particular type of rotor offers a wider field of operation compared with a traditional forward curved blade fan. When necessary, this can supply high static pressures simply by varying the number of revolutions. The accurate balancing and the self-lubricating bearings ensure its rotating stability over time.



The efficiency of the electronic controlled motor

The external rotor electric motor is driven by the continuous magnetic switching of the stator. The advantages are:

- the lack of brushes and the particular power supply increase efficiency by 70%;
- increase in the working life, thanks to the elimination of the brush wear;
- drastic reduction at the start-up of the starting current thanks to the electronic fan with the "soft start" function.



Advantages of direct coupling (plug fan)

The motor's rotation is transmitted directly to the rotor, without the use of transmissions (belts and pulleys):

- the transmissions' inefficiencies are eliminated;
- the transmissions' wear and maintenance is eliminated.

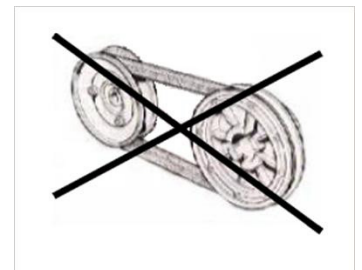

Efficiency of the ventilation system increases by 30%

The comprehensive ventilation system, made up of rotor and motor, is therefore very versatile and efficient.

Consumption is 30% lower than a ventilation system of the same capacity used by traditional units available on the market.

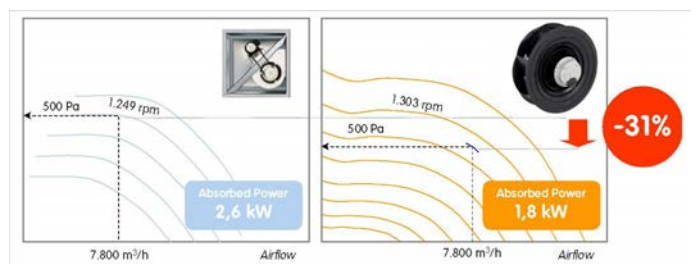

Electrical power absorption from the electric motor, manufacturer data - Example referred to the flow of 7,800 m³/h with static available pressure equal to 500 Pa

Higher levels of silence with composite

The fan impeller is made of a hybrid structure with aluminium alloy and plastic, with optimised aerodynamic blades. Thus electric absorption from the motor is reduced, obtaining a high level of silence whilst operating. This further technological progress increases the advantages in comparison with traditional centrifugal fans.



Reliability and saving throughout the entire life-cycle

System industrialisation

The unit may be supplied complete with the functions and components which are often supplied with the system. Thus reducing:

- design time: all the accessories are created to guarantee the best overall performance;
- installation costs: the accessories which are already mechanically connected, electrically wired and individually checked are ready to start operating immediately;
- dimensions: integration of system members into the unit reduces technical spaces and increases the space available for other uses. Its compact structure allows the unit to be carried through the shaft doors and to be positioned in service corridors.

The fan section is removable for an easier transport.

The whole upper part of the unit is easily removable. The reduction of the unit height and weight simplify its handling and transport.

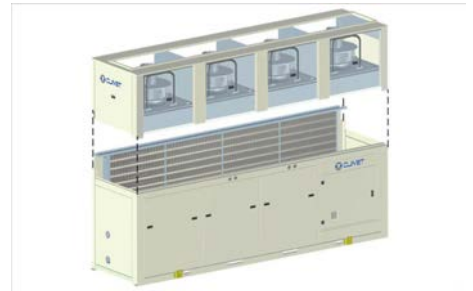

The built-in pumps are versatile, ready-for-use and reliable

The optional hydronic assembly is complete with everything required for the system start-up and operating: antifreeze heaters, safety valve, charge/drain valves, pressure gauges. It also includes the pumping unit with the following solutions:

- Standard pump, with a wide range of available heads.
- HYDROPACK, the modular solution with two or three parallel pumps. Automatically reduces the water flow when in critical conditions, thereby preventing jams due to overloading, requiring the subsequent intervention of specialised technical personnel. It is very useful during start-ups, when restarting after operating breaks (e.g. at the weekend) or after a long period of inactivity.

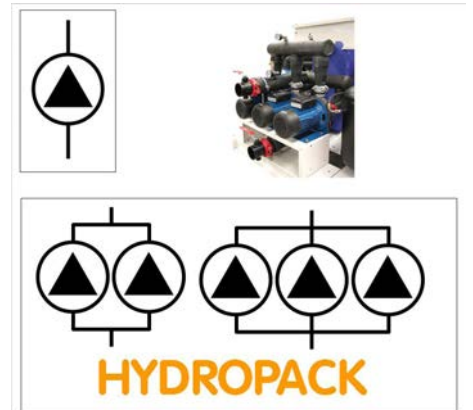

The exceptional HydroPack operation continuity

Due to its modularity, HYDROPACK maintains good water flow in the system even in the event of one of the pumps being temporarily unavailable.

In fact, with a deactivated pump, the residual flow is:

- about 80% of the rated flow (3 pump configuration)
- about 60% of the rated flow (2 pump configuration)

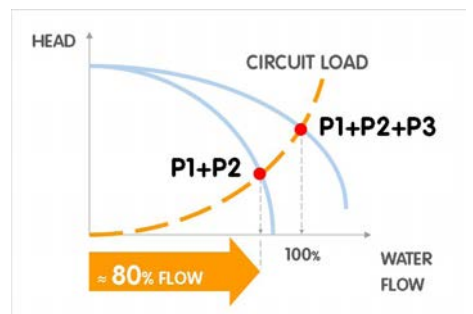

Start-up simplification with quick water connections

The units are complete with quick connections on the hydraulic side, which further reduce start-up times by eliminating pipe threading operations.

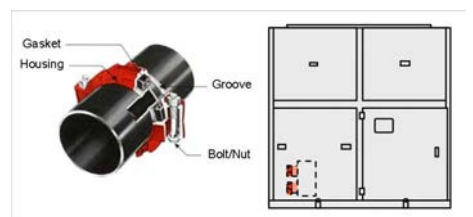

THE QUICK CONNECTIONS ARE STANDARD SUPPLIED

The right air flow for every type of system

By setting the fan speed on the display, it is possible to modify the air flow, adapting the head yield to the pressure drop carried out by the system and thus, simplifying the start up of the unit. It is no longer necessary to calibrate or modify the transmissions in as much as it is the fan system which adapts to the system.



Controlled power supply

Proper power supply ensures optimal unit operation and protects its many electrical components.

The phase monitor, standard supplied:

- controls the presence and the exact sequence of the phases
- checks any voltage anomalies (-10%)
- automatically restarts the unit as soon as the proper power supply is restored.

A multifunction monitor is available as an extra, where limit values and the service schedule of Clivet's Technical Support can be modified.



Demand limit

The partial or total activation of the compressors can be disabled to limit the overall electric capacity absorbed

The external signal is of analogical type 0-10 V / 4-20 mA. The greater the signal, the lower the capacity that the unit is enabled to deliver, activating the compressors and fans.

The Demand Limit function does not act on the control.

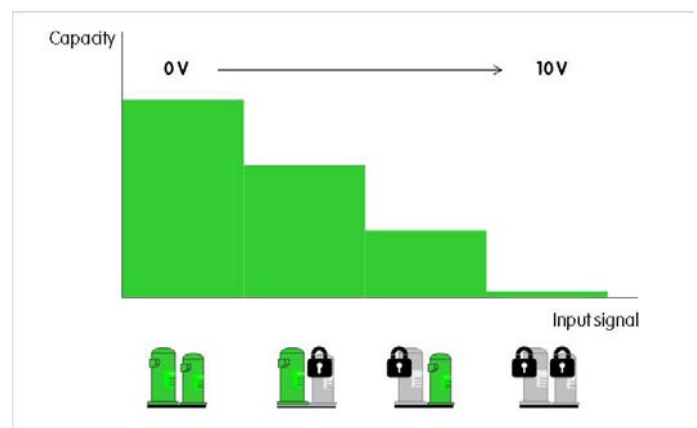

Modularity

In the event of particularly large buildings requiring high capacities, it is advisable to use several units.

The SPICHILLER² units are designed to be connected in parallel in modular logic, thereby granting the following advantages:

- Increased flexibility, enhanced by the control that can adapt to the load
- Increased reliability, since the malfunction of one unit does not compromise the capacity supply of the other units.
- Increased efficiency, since energy is produced where and when required, according to the served area.

The microprocessor control combined with ECOSHARE allows controlling up to 7 units in local network (1 Master unit and 6 Slave).

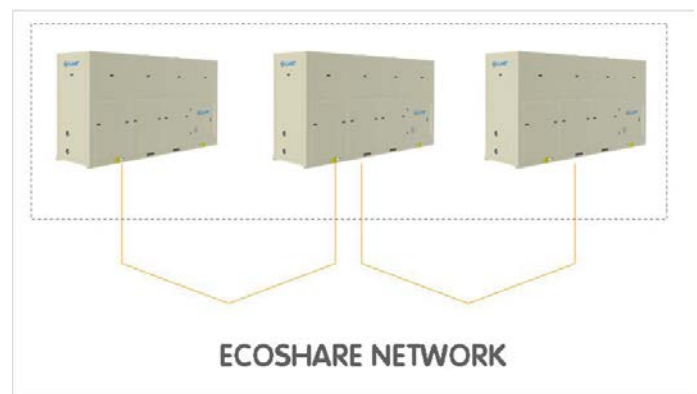

MODULAR SYSTEM THAT ENHANCES SPINCHILLER² TECHNOLOGY ADVANTAGES

Remote system management

The unit can be remotely managed by:

- Remote control with user interface
- Clivet P-Matic, supervision system able to be interfaced to other users
- Clean contacts are supplied as standard for remote on/off control, compressor state display, enabling/disabling refrigerant circuit and any remote alarms
- Different communication protocols to exchange information with the main supervision systems by serial line.



Energy measuring

Monitoring energy consumption and instant power employed is the starting point to improve the system's energy management and efficiency. With the optional energy meter, the user displays all the information related to the unit's electrical parameters on the interface built-in the unit or via the serial connection.



Efficient use of energy with heat recovery

In almost all systems fitted with a chiller used to produce chilled water there is also the need to have hot water. The recovery of condensation heat is an efficient way of producing hot water while the chiller is in operation. It has the double benefit of both reducing the heat load to the condenser, thereby eliminating dissipation costs and generating free hot water, thereby reducing the costs of the auxiliary heater.

Application versatility of recovery devices

The hot water produced by heat recovery can be used in a number of ways: to reheat air in handling units, to preheat hot water for domestic use or industrial processes, to heat up water in swimming pools, showers and spas, to preheat hot water for laundries or industrial kitchens.



Post-heating in air handling units to control humidity levels in hospitals and labs



Preheating of hot water for domestic use or for industrial process



Heating of water in swimming pools, showers and SPAS



Preheating of hot water for laundries and industrial kitchens

Water heating up

The heat recovery device can be used to cover the entire heat load required. The hot water supply temperature is controlled via a modulating control valve that needs to be fitted on the system at the outlet of the recovery unit. The auxiliary heating device is recommended to cover the thermal energy demand when the chiller is not in operation or is operating at part load.

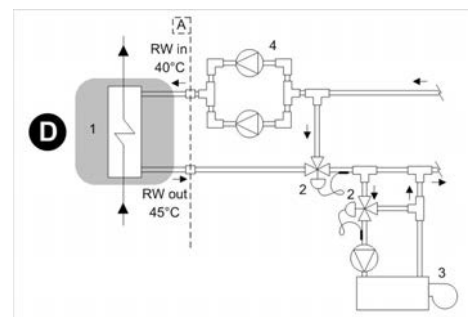

Example of how heat recovery is used to cover the entire heat demand and control the operating temperature

Water preheating

The heat recovery device can be used to preheat water at the inlet of the main heating device (e.g. boiler). In this case, the demand for hot water is greater than the amount of heat recovered by condensation and the recovery device only covers part of the required heat load. By preheating the water, heating consumption levels are therefore reduced and the main heating device has a lower installed power requirement.

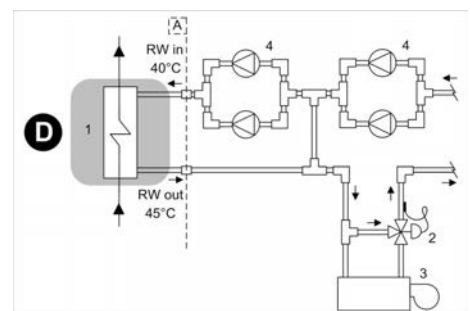

Example of how heat recovery is used to preheat hot water in the system

Domestic hot water production

The heat recovery device can be used to produce water for domestic use. In order to prevent contamination of domestic water with the chiller's process fluid, it is necessary to insert an intermediate heat exchanger. Using an inertial heat storage tank allows to have a reserve of preheated water and enables the intermediate exchanger to operate more efficiently.

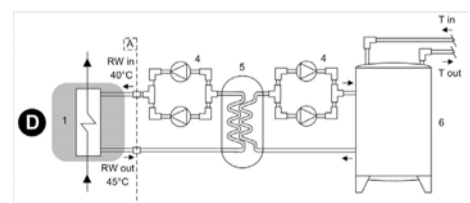

Example of how heat recovery is used to preheat hot water for domestic use

- A - Unit supply limit
- 1 - Recovery exchanger
- 3 - Auxiliary heating device (ex.boiler)
- 5 - Intermediate heat exchanger
- RW in - Recovery water input
- T in - Drinkable water inlet

- D - Partial energy recovery
- 2 - Control modulating valve
- 4 - Electric pump with standby pump
- 6 - Inertial heat storage
- RW out - Recovery water output
- T out - Drinkable water outlet to the auxiliary heater

The diagrams refer to partial energy recovery, though they also apply to total energy recovery (Clivet R). Please note that the diagrams are only meant as a guide.

Standard unit technical specifications

Compressor

Hermetic orbiting scroll compressor complete with motor over-temperature and over-current devices and protection against excessive gas discharge temperature. Fitted on rubber antivibration mounts and complete with oil charge.

An oil heater, which starts automatically, keeps the oil from being diluted by the refrigerant when the compressor stops.

The compressors are connected in TANDEM on a single refrigeration circuit and have a biphasic oil equalisation.

Structure

Supporting structure realised in galvanised steel sheet able to supply excellent mechanical features and long-lasting resistance to corrosion.

The fan section is easily disassembled by removing the fixing screws and the electrical rapid connectors, thus reducing the height of the unit during transport operations.

Panelling

External panelling with pre-painted panels covered with thermo-insulating and soundproofing material.

The housing panels can be removed by unbolting them and using the handles.

Internal Exchanger

Direct expansion heat exchanger with braze welded stainless steel INOX AISI 316 plates and complete with external thermal/anti-condensation insulation.

the exchanger comes complete with:

- differential pressure switch, water side
- antifreeze heater to protect the water side exchanger, preventing the formation of frost if the water temperature falls below a set value.

External exchanger

Finned coil exchanger made with copper pipes placed on staggered rows mechanically expanded to better adhere to the fin collar. The fins are made from aluminium with a corrugated surface and adequately distanced to ensure the maximum heat exchange efficiency.

Correct power supply to the expansion valve is ensured by the under-cooling circuit.

Protective coverings available on request.

Fan

ECOBREEZE device (STD)

Plug fans without scroll with reverse blades driven by electronically-controlled "brushless" DC motors with direct coupling.

Refrigeration circuit

Refrigeration circuit with:

- replaceable anti-acid solid cartridge dehydrator filter
- sight glass with moisture and liquid indicator
- electronic expansion valve
- high pressure safety pressure switch
- low pressure safety switch
- high pressure safety valve
- low pressure safety valve
- cutoff valve on liquid line
- cutoff valve on compressor supply

Electrical panel

The capacity section includes:

- main door lock isolator switch
- isolating transformer for auxiliary circuit power supply
- compressor circuit breakers
- fan overload circuit breakers
- compressor control contactor

The control section includes:

- interface terminal with graphic display
- display of the set values, the error codes and the parameter index
- ON/OFF and alarm reset buttons
- derivative-integral-proportional control of the water temperature
- daily, weekly programmer of the temperature set-point and local-remote unit switch on management
- antifreeze protection water side
- compressor overload protection and timer
- prealarm function for water anti-ice and high refrigerant gas pressure
- self-diagnosis system with immediate display of the error code
- automatic compressor start rotation control
- compressor operating hour display
- remote ON/OFF control
- relay for remote cumulative fault signal
- inlet for demand limit (power input limitation according to a 0÷10V external signal)
- potential-free contacts for compressor status
- digital input for double set-point enabling
- phase monitor

Configurations

- D - Partial energy recovery
- R - Total energy recovery
- B - Low water temperature

Accessories - hydronic assembly

- standard pump (n.b.: other types are available by head)
- HYDROPACK (n.b.: other types are available by head)
- couple of manual shut-off valves (accessory provided separately)
- steel mesh mechanical strainer (accessory separately supplied)

(note: to be located at the exchanger inlet. We disclaim any liability and make the guarantee void, if an appropriate mechanical filter is not provided inside the system)

Accessories

- finned coil protection grilles and shaft
- copper / aluminium condensing coil with acrylic lining
- copper / aluminium condensing coils with Aluminum Energy Guard DCC treatment
- high and low pressure gauges
- cutoff valve on compressor supply and return
- flush hydraulic connections
- electrical panel ventilation
- multifunction phase monitor
- power factor correction capacitors ($\cos\phi > 0.9$)
- ECOSHARE function for the automatic management of a group of units
- starting current reduction device (soft start)
- serial communication module for BACnet supervisor
- serial communication module for Modbus supervisor
- serial communication module for LonWorks supervisor
- microprocessor remote control unit (accessory separately supplied)
- remote control via microprocessor remote control (accessory separately supplied)
- mains power supply
- energy meter
- set-point compensation with 0–10 V signal
- set-point compensation with outdoor air temperature probe
- spring antivibration mounts (accessory separately supplied)

On request are available:

- copper /copper condensing coil

Test

All the units are factory-tested in specific steps, before shipping them. After the approval, the moisture contents present in all circuits are analyzed, in order to ensure the respect of the limits set by the manufacturers of the different components.



Unit for indoors installation only, away from atmospheric agents

General technical data

| Size | | | 432 | 452 | 552 | 602 | 702 | 80D | 90D | 100D | 110D | 120D |
|-----------------------------------|---|-------|----------|----------|----------|----------|----------|----------|----------|----------|----------|----------|
| Cooling | | | | | | | | | | | | |
| Cooling capacity | 1 | kW | 116 | 123 | 148 | 165 | 185 | 206 | 240 | 269 | 296 | 315 |
| Compressor power input | 1 | kW | 37.4 | 40.6 | 49.4 | 55.2 | 62.0 | 69.4 | 80.3 | 90.8 | 100 | 115 |
| Total power input | 2 | kW | 41.5 | 44.7 | 53.4 | 59.2 | 67.3 | 74.7 | 86.8 | 97.3 | 107 | 124 |
| Total recovery heating capacity | 3 | kW | 144 | 154 | 185 | 207 | 232 | 259 | 301 | 338 | 372 | 404 |
| Partial recovery heating capacity | 3 | kW | 30.7 | 32.8 | 39.4 | 44.0 | 49.4 | 55.0 | 64.1 | 71.9 | 79.2 | 85.9 |
| EER | 1 | | 2.79 | 2.76 | 2.76 | 2.78 | 2.75 | 2.75 | 2.77 | 2.76 | 2.76 | 2.54 |
| Cooling capacity (EN14511:2011) | 4 | kW | 115 | 123 | 147 | 164 | 184 | 205 | 239 | 268 | 295 | 313 |
| Total power input (EN14511:2011) | 4 | kW | 41.9 | 45.1 | 54.0 | 59.9 | 68.0 | 75.5 | 87.9 | 98.3 | 108 | 125 |
| EER (EN 14511:2011) | 4 | | 2.76 | 2.73 | 2.72 | 2.74 | 2.71 | 2.71 | 2.72 | 2.73 | 2.73 | 2.51 |
| ESEER | 4 | | 4.24 | 4.13 | 4.07 | 4.11 | 4.26 | 4.41 | 4.18 | 4.15 | 4.16 | 3.92 |
| Compressor | | | | | | | | | | | | |
| Type of compressors | | | SCROLL | SCROLL | SCROLL | SCROLL | SCROLL | SCROLL | SCROLL | SCROLL | SCROLL | SCROLL |
| No. of compressors | | No | 2 | 2 | 2 | 2 | 2 | 4 | 4 | 4 | 4 | 4 |
| Rated power (C1) | | HP | 43 | 45 | 55 | 60 | 70 | 40 | 45 | 50 | 55 | 60 |
| Nominal capacity (C2) | | HP | - | - | - | - | - | 40 | 45 | 50 | 55 | 60 |
| Std Capacity control steps | | No | 3 | 3 | 3 | 2 | 3 | 6 | 6 | 6 | 6 | 4 |
| Oil charge (C1) | | l | 12.0 | 10.0 | 13.0 | 13.0 | 13.0 | 10.0 | 10.0 | 11.0 | 13.0 | 13.0 |
| Oil charge (C2) | | l | - | - | - | - | - | 10.0 | 10.0 | 11.0 | 13.0 | 13.0 |
| Refrigerant charge (C1) | 5 | kg | 24 | 24 | 24 | 24 | 32 | 16 | 20 | 20 | 20 | 20 |
| Refrigerant charge (C2) | 5 | kg | - | - | - | - | - | 16 | 20 | 20 | 20 | 20 |
| Refrigeration circuits | | No | 1 | 1 | 1 | 1 | 1 | 2 | 2 | 2 | 2 | 2 |
| Internal exchanger | | | | | | | | | | | | |
| Type of internal exchanger | 6 | | PHE | PHE | PHE | PHE | PHE | PHE | PHE | PHE | PHE | PHE |
| Water flow rate (Utility Side) | 4 | l/s | 5.50 | 5.90 | 7.00 | 7.80 | 8.80 | 9.80 | 11.4 | 12.8 | 14.1 | 15.0 |
| Internal exchanger pressure drops | 4 | kPa | 28 | 26 | 36 | 36 | 45 | 55 | 58 | 49 | 60 | 59 |
| Water content | | l | 8.90 | 10.1 | 10.1 | 11.9 | 11.9 | 10.5 | 12.9 | 17.6 | 20.1 | 20.1 |
| External Section Fans | | | | | | | | | | | | |
| Type of fans | 7 | | RAD | RAD | RAD | RAD | RAD | RAD | RAD | RAD | RAD | RAD |
| Number of fans | | No | 3 | 3 | 3 | 3 | 4 | 4 | 5 | 5 | 5 | 5 |
| Standard airflow | | l/s | 12333 | 12333 | 12333 | 12333 | 16444 | 16444 | 20556 | 20556 | 21389 | 22222 |
| Connections | | | | | | | | | | | | |
| Water connections | | | 2" 1/2 | 2" 1/2 | 2" 1/2 | 2" 1/2 | 2" 1/2 | 3" | 3" | 4" | 4" | 4" |
| Power supply | | | | | | | | | | | | |
| Standard power supply | | V | 400/3/50 | 400/3/50 | 400/3/50 | 400/3/50 | 400/3/50 | 400/3/50 | 400/3/50 | 400/3/50 | 400/3/50 | 400/3/50 |
| Noise Levels | | | | | | | | | | | | |
| Sound power in the duct | 8 | dB(A) | 92 | 92 | 92 | 92 | 93 | 93 | 95 | 95 | 96 | 97 |
| Dimensions | | | | | | | | | | | | |
| A - Length | | mm | 3312 | 3312 | 3312 | 3312 | 4400 | 4400 | 5486 | 5486 | 5486 | 5486 |
| B - Width | | mm | 1151 | 1151 | 1151 | 1151 | 1151 | 1151 | 1151 | 1151 | 1151 | 1151 |
| C - Height | | mm | 2312 | 2312 | 2312 | 2312 | 2312 | 2312 | 2312 | 2312 | 2312 | 2312 |
| Standard unit weights | | | | | | | | | | | | |
| Shipping weight | | kg | 1408 | 1359 | 1482 | 1545 | 1831 | 1967 | 2331 | 2513 | 2642 | 2684 |
| Operating weight | | kg | 1430 | 1384 | 1507 | 1573 | 1861 | 1994 | 2369 | 2561 | 2695 | 2737 |

1. Data refer to the following conditions: - internal water exchanger = 12/7 °C - outdoor air temperature 35°C
2. The Total Power Input value does not take into account the part related to the pumps and required to overcome the pressure drops for the circulation of the solution inside the exchangers
3. Option. Recovery exchanger water = 40/45°C
4. Data calculated in compliance with Standard EN 14511:2011 referred to the following conditions: - Internal exchanger water temperature = 12/7°C - external exchanger intake air temperature = 35°C

5. indicative values for standard units with possible +/-10% variation. The actual data are indicated on the label of the unit.
6. PHE = plate exchanger
7. RAD = radial fan
8. Sound power measured in accordance with UNI EN ISO 9614 and Eurovent 8/1 standards for ducted unit with available pressure equal to 120 Pa.

Electrical data

| Size | | 432 | 452 | 552 | 602 | 702 | 80D | 90D | 100D | 110D | 120D |
|--|----|------|------|------|------|-----|-----|-----|------|------|------|
| F.L.A. - Full load current at max admissible conditions | | | | | | | | | | | |
| F.L.A. - Total | A | 104 | 112 | 126 | 141 | 163 | 181 | 217 | 228 | 245 | 274 |
| F.L.I. Full load power input at max admissible conditions | | | | | | | | | | | |
| F.L.I. - Total | kW | 64.1 | 67.5 | 77.7 | 86.5 | 102 | 108 | 130 | 141 | 150 | 168 |
| M.I.C. Maximum inrush current | | | | | | | | | | | |
| M.I.C. - Value | A | 331 | 363 | 377 | 392 | 483 | 408 | 468 | 479 | 496 | 525 |
| M.I.C. with soft start accessory | A | 198 | 226 | 240 | 254 | 311 | 276 | 330 | 342 | 358 | 387 |

Voltage unbalance: max 2 %
 Power supply: 400/3/50 Hz +/- 10%

Electrical data refer to standard units; according to the installed accessories, the data can suffer light variations.

Operating range

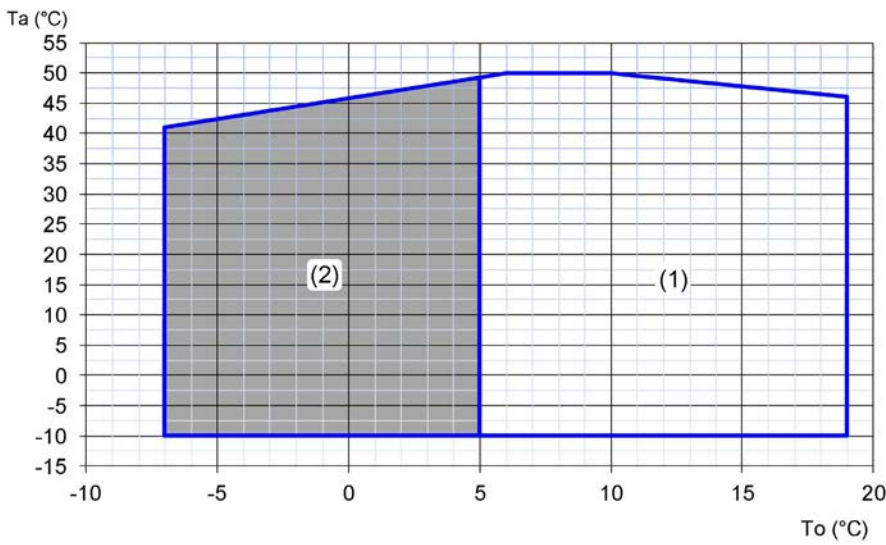

Ta (°C)= external exchanger inlet air temperature (D.B.)

To (°C)= internal exchanger outlet water temperature

1 = Standard unit operating range

2 = Unit operating range in 'B - Liquid low temperature' configuration(40% ethylene glycol)

In the unit operating at part load the outdoor air minimum temperature limit is -7°C.

| Water temperature to the internal exchanger | | |
|---|---|-------|
| Max inlet water temperature | 1 | 24 °C |
| Min. outlet water temperature | 2 | 5 °C |
| Min. outlet water temperature | 3 | -7 °C |

- Standard unit. External exchanger intake air temperature 35°C
- Standard unit. External exchanger intake air temperature 35°C
- Unit in 'Low water temperature (Brine)' configuration and air (35 °C) entering the external heat exchanger. 40% ethylene glycol based water.

Performances in cooling

| Size | To (°) | Outdoor air temperature | | | | | | | | | |
|------|--------|-------------------------|------|-----|------|-----|------|-----|------|------|------|
| | | 25 | | 30 | | 35 | | 40 | | 45 | |
| | | kWf | kWe | kWf | kWe | kWf | kWe | kWf | kWe | kWf | kWe |
| 432 | 6 | 128 | 31.3 | 121 | 34.0 | 113 | 37.2 | 105 | 40.5 | 98.0 | 44.7 |
| | 7 | 131 | 31.5 | 124 | 34.3 | 116 | 37.4 | 107 | 41.0 | 101 | 45.2 |
| | 8 | 135 | 32.0 | 127 | 34.7 | 119 | 37.9 | 111 | 41.3 | 104 | 45.3 |
| | 9 | 139 | 32.1 | 131 | 35.1 | 122 | 38.4 | 113 | 41.7 | 107 | 45.8 |
| | 10 | 142 | 32.5 | 135 | 35.5 | 125 | 38.6 | 116 | 42.1 | 110 | 46.3 |
| | 11 | 146 | 33.0 | 137 | 35.7 | 130 | 39.0 | 120 | 42.6 | 115 | 46.9 |
| 452 | 6 | 137 | 33.7 | 129 | 36.9 | 120 | 40.1 | 111 | 43.7 | 105 | 48.1 |
| | 7 | 142 | 34.2 | 132 | 37.3 | 123 | 40.6 | 114 | 44.3 | 108 | 48.4 |
| | 8 | 145 | 34.4 | 135 | 37.6 | 126 | 40.9 | 117 | 44.6 | 111 | 48.7 |
| | 9 | 148 | 34.8 | 139 | 37.8 | 129 | 41.3 | 120 | 44.8 | 114 | 49.1 |
| | 10 | 152 | 35.3 | 142 | 38.5 | 133 | 41.7 | 122 | 45.4 | 119 | 50.1 |
| | 11 | 156 | 35.7 | 147 | 39.0 | 136 | 42.3 | 127 | 45.9 | 124 | 50.7 |
| 552 | 6 | 165 | 41.2 | 155 | 44.7 | 144 | 49.0 | 133 | 53.5 | 127 | 58.5 |
| | 7 | 170 | 41.9 | 159 | 45.4 | 148 | 49.4 | 137 | 53.8 | 131 | 59.0 |
| | 8 | 173 | 42.3 | 163 | 45.7 | 151 | 49.9 | 141 | 54.2 | 134 | 59.3 |
| | 9 | 177 | 42.6 | 167 | 46.2 | 155 | 50.2 | 144 | 54.8 | 139 | 60.4 |
| | 10 | 181 | 43.0 | 170 | 47.0 | 158 | 50.9 | 147 | 55.1 | 143 | 60.7 |
| | 11 | 186 | 43.7 | 174 | 47.5 | 162 | 51.4 | 153 | 56.0 | 151 | 61.7 |
| 602 | 6 | 183 | 45.9 | 173 | 50.1 | 160 | 54.8 | 148 | 59.9 | 140 | 65.3 |
| | 7 | 188 | 46.5 | 176 | 50.6 | 165 | 55.2 | 154 | 60.2 | 146 | 66.0 |
| | 8 | 194 | 47.3 | 183 | 51.2 | 170 | 55.8 | 156 | 61.0 | 150 | 66.7 |
| | 9 | 197 | 47.8 | 186 | 51.7 | 172 | 56.5 | 161 | 61.3 | 155 | 67.8 |
| | 10 | 202 | 48.3 | 190 | 52.4 | 177 | 56.8 | 167 | 62.2 | 162 | 68.8 |
| | 11 | 209 | 49.1 | 197 | 53.4 | 182 | 57.8 | 170 | 62.7 | 167 | 69.0 |
| 702 | 6 | 205 | 51.4 | 194 | 56.3 | 180 | 61.5 | 167 | 66.8 | 158 | 73.6 |
| | 7 | 212 | 52.1 | 199 | 56.9 | 185 | 62.0 | 172 | 67.8 | 163 | 73.9 |
| | 8 | 217 | 52.7 | 203 | 57.5 | 190 | 62.7 | 177 | 68.3 | 168 | 74.8 |
| | 9 | 222 | 53.4 | 208 | 58.1 | 195 | 63.1 | 181 | 69.1 | 175 | 76.0 |
| | 10 | 227 | 54.0 | 213 | 58.9 | 199 | 63.9 | 184 | 69.5 | 180 | 76.7 |
| | 11 | 233 | 54.6 | 220 | 59.6 | 205 | 64.8 | 192 | 70.3 | 189 | 77.8 |
| 80D | 6 | 228 | 58.1 | 215 | 63.3 | 200 | 69.0 | 185 | 75.1 | 177 | 82.4 |
| | 7 | 234 | 58.8 | 221 | 63.9 | 206 | 69.4 | 191 | 76.0 | 182 | 82.6 |
| | 8 | 242 | 59.5 | 227 | 64.6 | 210 | 70.1 | 196 | 76.4 | 188 | 83.4 |
| | 9 | 246 | 60.1 | 231 | 65.1 | 214 | 70.5 | 200 | 76.9 | 193 | 84.7 |
| | 10 | 249 | 60.7 | 236 | 65.8 | 219 | 71.6 | 205 | 77.8 | 199 | 85.1 |
| | 11 | 257 | 61.4 | 241 | 66.6 | 225 | 72.1 | 211 | 78.3 | 210 | 86.5 |
| 90D | 6 | 264 | 66.8 | 250 | 72.8 | 233 | 79.3 | 216 | 86.4 | 203 | 94.7 |
| | 7 | 273 | 67.8 | 258 | 73.6 | 240 | 80.3 | 222 | 87.5 | 209 | 95.6 |
| | 8 | 280 | 68.2 | 264 | 74.4 | 245 | 81.2 | 227 | 87.8 | 215 | 96.4 |
| | 9 | 285 | 68.9 | 268 | 75.2 | 248 | 81.7 | 231 | 88.6 | 219 | 97.3 |
| | 10 | 290 | 69.7 | 274 | 75.6 | 254 | 82.3 | 236 | 89.6 | 226 | 97.6 |
| | 11 | 296 | 70.5 | 280 | 76.4 | 261 | 82.7 | 242 | 90.2 | 233 | 98.6 |
| 100D | 6 | 301 | 75.6 | 282 | 82.1 | 263 | 89.8 | 244 | 98.2 | 233 | 108 |
| | 7 | 309 | 76.9 | 289 | 83.0 | 269 | 90.8 | 251 | 98.8 | 241 | 109 |
| | 8 | 315 | 77.7 | 296 | 84.0 | 274 | 91.4 | 255 | 99.7 | 247 | 111 |
| | 9 | 321 | 78.1 | 300 | 84.9 | 278 | 92.0 | 260 | 101 | 255 | 112 |
| | 10 | 326 | 78.9 | 306 | 85.9 | 285 | 93.4 | 268 | 101 | 268 | 114 |
| | 11 | 336 | 80.3 | 317 | 86.9 | 293 | 94.1 | 277 | 102 | 275 | 114 |
| 110D | 6 | 330 | 83.3 | 310 | 90.3 | 288 | 98.6 | 267 | 108 | 254 | 118 |
| | 7 | 338 | 84.2 | 317 | 91.4 | 296 | 99.7 | 276 | 109 | 266 | 121 |
| | 8 | 347 | 85.1 | 326 | 92.4 | 303 | 99.4 | 280 | 110 | 271 | 121 |
| | 9 | 352 | 85.5 | 329 | 93.3 | 306 | 101 | 284 | 110 | 279 | 122 |
| | 10 | 357 | 86.4 | 335 | 94.4 | 315 | 103 | 294 | 111 | 292 | 123 |
| | 11 | 369 | 88.3 | 347 | 95.5 | 323 | 104 | 302 | 112 | 318 | 128 |

| Size | To (°C) | Outdoor air temperature | | | | | | | | | |
|------|---------|-------------------------|------|-----|-----|-----|-----|-----|-----|-----|-----|
| | | 25 | | 30 | | 35 | | 40 | | 45 | |
| | | kWf | kWe | kWf | kWe | kWf | kWe | kWf | kWe | kWf | kWe |
| 120D | 6 | 354 | 95.8 | 332 | 104 | 308 | 114 | 288 | 124 | 282 | 138 |
| | 7 | 363 | 96.8 | 340 | 106 | 315 | 115 | 296 | 125 | 298 | 141 |
| | 8 | 370 | 98.4 | 350 | 107 | 323 | 116 | 303 | 126 | 300 | 139 |
| | 9 | 377 | 99.4 | 352 | 108 | 328 | 117 | 306 | 127 | 303 | 138 |
| | 10 | 384 | 99.9 | 358 | 109 | 334 | 118 | 316 | 129 | 324 | 143 |
| | 11 | 392 | 101 | 370 | 110 | 346 | 120 | 328 | 130 | 330 | 143 |

kWf = Cooling capacity in kW-the data do not consider the pump share, required to overcome the pressure drop for the solution circulation inside the exchangers

kWe = Compressor power input in kW

To = Internal exchanger water outlet temperature (°C)

Inlet/outlet water temperature differential = 5°C

Electric fan performance

| Size | Static available pressure (Pa) | 70 | 80 | 90 | 100 | 120 | 150 | 180 | 210 | 240 | 270 | 300 | 330 | |
|------|--------------------------------|-----|-------|-------|-------|-------|-------|-------|-------|-------|-------|-------|-------|-------|
| 432 | Standard airflow | l/s | 12333 | 12333 | 12333 | 12333 | 12333 | 12333 | 12333 | 12333 | 12333 | 12333 | 12333 | |
| | Fan RPM | rpm | 1599 | 1604 | 1609 | 1614 | 1624 | 1639 | 1655 | 1670 | 1686 | 1702 | 1718 | 1734 |
| | Total input | kW | 7,92 | 8,04 | 8,19 | 8,34 | 8,61 | 8,94 | 9,27 | 9,63 | 9,96 | 10,32 | 10,71 | 11,07 |
| 452 | Standard airflow | l/s | 12333 | 12333 | 12333 | 12333 | 12333 | 12333 | 12333 | 12333 | 12333 | 12333 | 12333 | |
| | Fan RPM | rpm | 1599 | 1604 | 1609 | 1614 | 1624 | 1639 | 1655 | 1670 | 1686 | 1702 | 1718 | 1734 |
| | Total input | kW | 7,92 | 8,04 | 8,19 | 8,34 | 8,61 | 8,94 | 9,27 | 9,63 | 9,96 | 10,32 | 10,71 | 11,07 |
| 552 | Standard airflow | l/s | 12333 | 12333 | 12333 | 12333 | 12333 | 12333 | 12333 | 12333 | 12333 | 12333 | 12333 | |
| | Fan RPM | rpm | 1615 | 1618 | 1627 | 1630 | 1637 | 1657 | 1672 | 1683 | 1699 | 1717 | 1735 | 1750 |
| | Total input | kW | 8,00 | 8,11 | 8,28 | 8,42 | 8,68 | 9,04 | 9,36 | 9,71 | 10,04 | 10,41 | 10,82 | 11,17 |
| 602 | Standard airflow | l/s | 12333 | 12333 | 12333 | 12333 | 12333 | 12333 | 12333 | 12333 | 12333 | 12333 | 12333 | |
| | Fan RPM | rpm | 1647 | 1654 | 1654 | 1664 | 1671 | 1688 | 1703 | 1718 | 1738 | 1750 | 1770 | 1786 |
| | Total input | kW | 8,16 | 8,29 | 8,42 | 8,60 | 8,86 | 9,21 | 9,54 | 9,91 | 10,27 | 10,61 | 11,03 | 11,40 |
| 702 | Standard airflow | l/s | 16444 | 16444 | 16444 | 16444 | 16444 | 16444 | 16444 | 16444 | 16444 | 16444 | 16444 | |
| | Fan RPM | rpm | 1631 | 1638 | 1638 | 1646 | 1658 | 1673 | 1686 | 1702 | 1716 | 1736 | 1754 | 1769 |
| | Total input | kW | 10,77 | 10,95 | 11,12 | 11,34 | 11,72 | 12,17 | 12,59 | 13,08 | 13,52 | 14,04 | 14,58 | 15,06 |
| 80D | Standard airflow | l/s | 16444 | 16444 | 16444 | 16444 | 16444 | 16444 | 16444 | 16444 | 16444 | 16444 | 16444 | |
| | Fan RPM | rpm | 1631 | 1638 | 1638 | 1646 | 1658 | 1673 | 1686 | 1702 | 1716 | 1736 | 1754 | 1769 |
| | Total input | kW | 10,77 | 10,95 | 11,12 | 11,34 | 11,72 | 12,17 | 12,59 | 13,08 | 13,52 | 14,04 | 14,58 | 15,06 |
| 90D | Standard airflow | l/s | 20555 | 20555 | 20555 | 20555 | 20555 | 20555 | 20555 | 20555 | 20555 | 20555 | 20555 | |
| | Fan RPM | rpm | 1629 | 1636 | 1643 | 1643 | 1656 | 1670 | 1688 | 1705 | 1721 | 1734 | 1752 | 1767 |
| | Total input | kW | 13,45 | 13,67 | 13,94 | 14,15 | 14,64 | 15,18 | 15,76 | 16,39 | 16,95 | 17,53 | 18,21 | 18,80 |
| 100D | Standard airflow | l/s | 20555 | 20555 | 20555 | 20555 | 20555 | 20555 | 20555 | 20555 | 20555 | 20555 | 20555 | |
| | Fan RPM | rpm | 1629 | 1636 | 1643 | 1643 | 1656 | 1670 | 1688 | 1705 | 1721 | 1734 | 1752 | 1767 |
| | Total input | kW | 13,45 | 13,67 | 13,94 | 14,15 | 14,64 | 15,18 | 15,76 | 16,39 | 16,95 | 17,53 | 18,21 | 18,80 |
| 110D | Standard airflow | l/s | 21388 | 21388 | 21388 | 21388 | 21388 | 21388 | 21388 | 21388 | 21388 | - | - | |
| | Fan RPM | rpm | 1658 | 1663 | 1667 | 1672 | 1682 | 1696 | 1711 | 1726 | 1741 | 1756 | - | - |
| | Total input | kW | 14,5 | 14,75 | 14,95 | 15,2 | 15,7 | 16,4 | 16,95 | 17,5 | 18,1 | 18,7 | - | - |
| 120D | Standard airflow | l/s | 22222 | 22222 | 22222 | 22222 | 22222 | 22222 | - | - | - | - | - | |
| | Fan RPM | rpm | 1713 | 1719 | 1724 | 1728 | 1738 | 1751 | - | - | - | - | - | - |
| | Total input | kW | 15,85 | 16,1 | 16,35 | 16,6 | 17,05 | 17,85 | - | - | - | - | - | - |

The performance has been calculated in relation to the internal pressure drop of a standard unit.

Correction factors for glycol use

| % ethylene glycol by weight | | 5% | 10% | 15% | 20% | 25% | 30% | 35% | 40% |
|--|----|-------|-------|-------|-------|-------|-------|-------|-------|
| Freezing temperature | °C | -2,0 | -3,9 | -6,5 | -8,9 | -11,8 | -15,6 | -19,0 | -23,4 |
| Safety temperature | °C | 3,0 | 1,0 | -1,0 | -4,0 | -6,0 | -10,0 | -14,0 | -19,0 |
| Cooling Capacity Factor | No | 0,995 | 0,99 | 0,985 | 0,981 | 0,977 | 0,974 | 0,971 | 0,968 |
| Compressor input Factor | No | 0,997 | 0,993 | 0,99 | 0,988 | 0,986 | 0,984 | 0,982 | 0,981 |
| Internal exchanger Glycol solution flow Factor | No | 1,003 | 1,01 | 1,02 | 1,033 | 1,05 | 1,072 | 1,095 | 1,124 |
| Pressure drop Factor | No | 1,029 | 1,06 | 1,09 | 1,118 | 1,149 | 1,182 | 1,211 | 1,243 |

The correction factors shown refer to water and glycol ethylene mixes used to prevent the formation of frost on the exchangers in the water circuit during inactivity in winter.

Fouling Correction Factors

| m ² °C / W | Internal exchanger | |
|-----------------------|--------------------|------|
| | F1 | FK1 |
| 0.44 x 10 (-4) | 1,0 | 1,0 |
| 0.88 x 10 (-4) | 0,97 | 0,99 |
| 1.76 x 10 (-4) | 0,94 | 0,98 |

The cooling performance values provided in the tables are based on the external exchanger having clean plates (fouling factor 1). For different fouling factor values, multiply the performance by the coefficients shown in the table.

F1 = Cooling capacity correction factors
FK1 = Compressor power input correction factor

Internal exchanger pressure drops

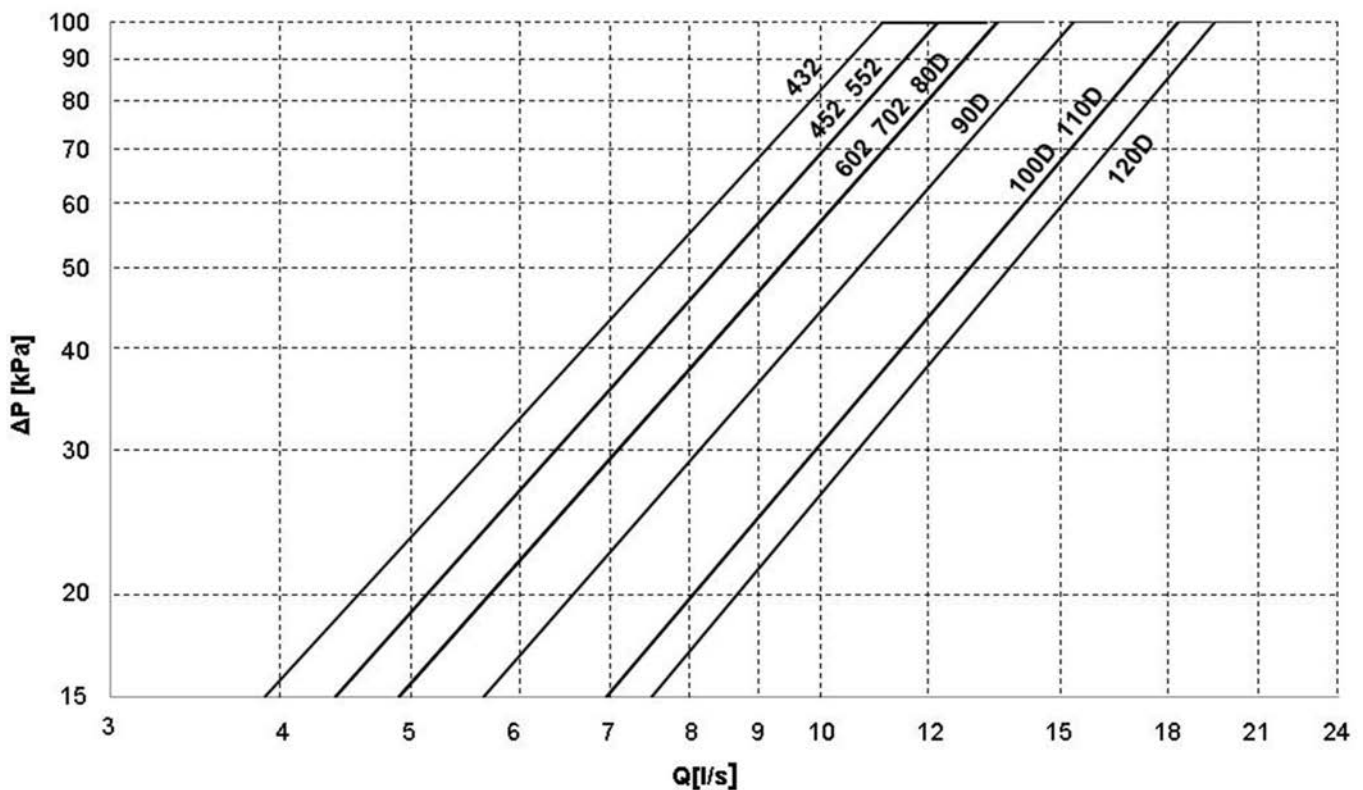

The pressure drops, water side, are calculated considering an average water temperature of 7°C.

Q = water flow rate [l/s]

DP = pressure drop [kPa]

The water flow rate must be calculated with the following formula

$Q [l/s] = kWf / (4,186 \times DT)$

kWf = Cooling capacity in kW

DT = Temperature difference between inlet / outlet water



To the internal exchanger pressure drops must be added the pressure drops of the mechanical steel mesh strainer that must be placed on the water input line. It is a device compulsory for the correct unit operation, and it is available as Clivet option. (See the HYDRONIC ASSEMBLY ACCESSORIES). If the mechanical strainer is selected and installed by the Customer, it is forbidden the use of filters with the mesh pitch higher than 1,6 mm, because they can cause a bad unit operation and also its serious damaging.

Admissible water flow rates

Minimum (Qmin) and maximum (Qmax) admissible water flow for the unit to operate correctly.

| Size | | 432 | 452 | 552 | 602 | 702 | 80D | 90D | 100D | 110D | 120D |
|------|-------|------|------|------|------|------|------|------|------|------|------|
| Qmin | [l/s] | 3,9 | 4,4 | 4,4 | 4,9 | 4,9 | 4,9 | 5,6 | 7,0 | 7,0 | 7,5 |
| Qmax | [l/s] | 11,1 | 12,2 | 12,2 | 13,5 | 13,5 | 13,5 | 15,3 | 18,3 | 18,3 | 19,5 |

Exchanger operating range

| Internal exchanger | | | |
|--------------------|-----|------|------|
| PED (CE) | kPa | DPr | DPw |
| | | 4500 | 1000 |

DPr = Max. operating pressure refrigerant gas side

DPw = Max. operating pressure water side (utility)

Attention! For different approvals contact our sales office

Overload and control device calibrations

| | | open | closed | Value |
|--|-------|------|--------|-------|
| High pressure switch | [kPa] | 4050 | 3300 | – |
| Low pressure switch | [kPa] | 450 | 600 | – |
| Low pressure switch (Brine and FCD) | [kPa] | 200 | 350 | – |
| Antifreeze protection | [°C] | 3 | 5,5 | – |
| High pressure safety valve | [kPa] | – | – | 4500 |
| Low pressure safety valve | [kPa] | – | – | 3000 |
| Max no. of compressor starts per hour | [n°] | – | – | 10 |
| High discharge temperature safety thermostat | [°C] | – | – | 120 |

Sound levels

| Size | Sound power level (dB) | | | | | | | | Sound power level | Sound pressure level |
|------|------------------------|-----|-----|-----|------|------|------|------|-------------------|----------------------|
| | Octave band (Hz) | | | | | | | | | |
| | 63 | 125 | 250 | 500 | 1000 | 2000 | 4000 | 8000 | | |
| 432 | 69 | 76 | 92 | 87 | 85 | 86 | 79 | 76 | 95 | 76 |
| 452 | 69 | 76 | 91 | 87 | 85 | 86 | 79 | 76 | 95 | 76 |
| 552 | 69 | 76 | 92 | 87 | 85 | 86 | 79 | 76 | 95 | 76 |
| 602 | 69 | 76 | 92 | 87 | 85 | 86 | 79 | 76 | 95 | 76 |
| 702 | 70 | 78 | 93 | 89 | 87 | 88 | 81 | 78 | 96 | 77 |
| 80D | 70 | 78 | 93 | 89 | 87 | 88 | 81 | 78 | 96 | 77 |
| 90D | 72 | 80 | 95 | 90 | 89 | 89 | 83 | 80 | 98 | 78 |
| 100D | 72 | 80 | 95 | 90 | 89 | 90 | 83 | 80 | 98 | 78 |
| 110D | 73 | 80 | 96 | 91 | 90 | 90 | 84 | 81 | 99 | 79 |
| 120D | 74 | 81 | 97 | 92 | 90 | 91 | 85 | 82 | 100 | 80 |

Sound levels refer to full load units, in test nominal conditions. The sound pressure level refers to 1 m. from the unit outer surface operating in open field.

(standard UNI EN ISO 9614-2)

Data referred to the following conditions:

Internal exchanger water temperature = 12/7°C

outdoor air temperature 35°C

Static available pressure 120 Pa

Please note that when the unit is installed in conditions different from nominal test conditions (e.g. near walls or obstacles in general), the sound levels may undergo substantial variations.

Configurations

Consult the special prospective reported in the final section to check for compatibility between different options.

EO - Horizontal air exhaust

Configuration which allows to reduce the height of the shaft where the unit is installed.

The air exhaust outlet, complete with coupling flange, is at the rear of the unit.

B - Water low temperature (Brine)

Configuration also known as “Brine”. Enables an “unfreezable” solution to be cooled (for example, water and ethylene glycol in suitable quantities) up to a temperature of between +4°C and -7°C.

It includes:

- suitable exchangers with extra-thick closed-cell insulation
- electronic expansion valve, functional calibration and safety devices suitable for particular uses.



During the selection phase it is necessary to indicate the required operating type, the unit will be optimised on the basis of this: - Unit with single operating set-point (only at low temperature) - Unit with double operating set-point



The unit in this configuration has a different operation range, indicated in the operating range section.



In low temperature operation, some staging steps could not be available.



The glycol concentration must be chosen based on the minimum temperature the water can reach. The presence of glycol influences pressure drops on the water side and the unit's output as indicated in the table reporting the “correction factors for use with glycol”.

D - Partial energy recovery

A configuration which enables the production of hot water free-of-charge while operating in the cooling mode, thanks to the partial recovery of condensation heat that would otherwise be disposed of into the external heat source.

This option is also known as “desuperheater”. It is made up of a Inox 316 stainless steel brazed plate heat exchangers, suitable for recovering a part of the capacity dispersed by the unit (the dispersed heating capacity is equal to the sum of the cooling capacity and the electrical input capacity of the compressors).

The partial recovery device is considered to be operating when it is powered by the water flow which is to be heated. This condition improves the unit performance, since it reduces the condensation temperature: in nominal conditions the cooling capacity increases indicatively by 3.2% and the power input of the compressors is reduced by 3.6%.

When the temperature of the water to be heated is particularly low, it is wise to insert a flow control valve into the system hydraulic circuit, in order to maintain the temperature at the recovery output at above 35°C and thus avoid the condensation of the refrigerant into the partial energy recovery device.

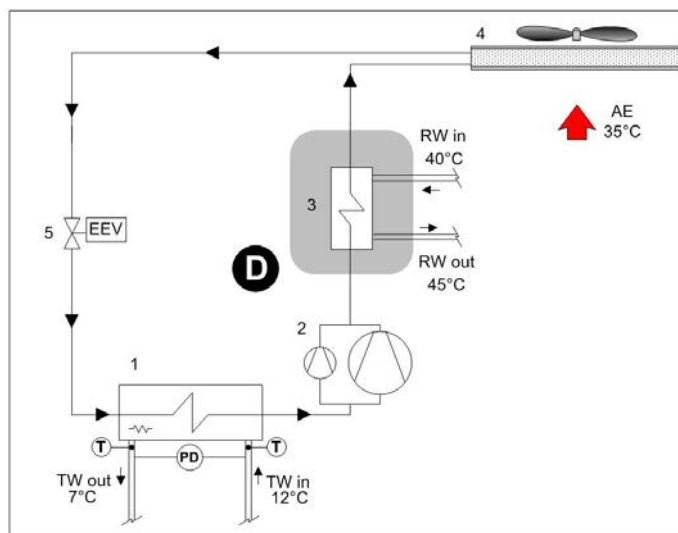

D - Partial recovery device

- 1 - Internal exchanger
- 2 - Compressors
- 3 - Recovery exchanger
- 4 - External exchanger
- 5 - Expansion electronic valve

TW in chilled water inlet
TW out chilled water outlet

RW in - Recovery water input
RW out - Recovery water output

T - Temperature probe
PD - Differential pressure switch
AE Outdoor air



The power delivered by the partial recovery is 20% of the thermal power dissipation (cooling + electrical power absorbed by the compressors)

Pressure drops of partial energy recovery exchanger

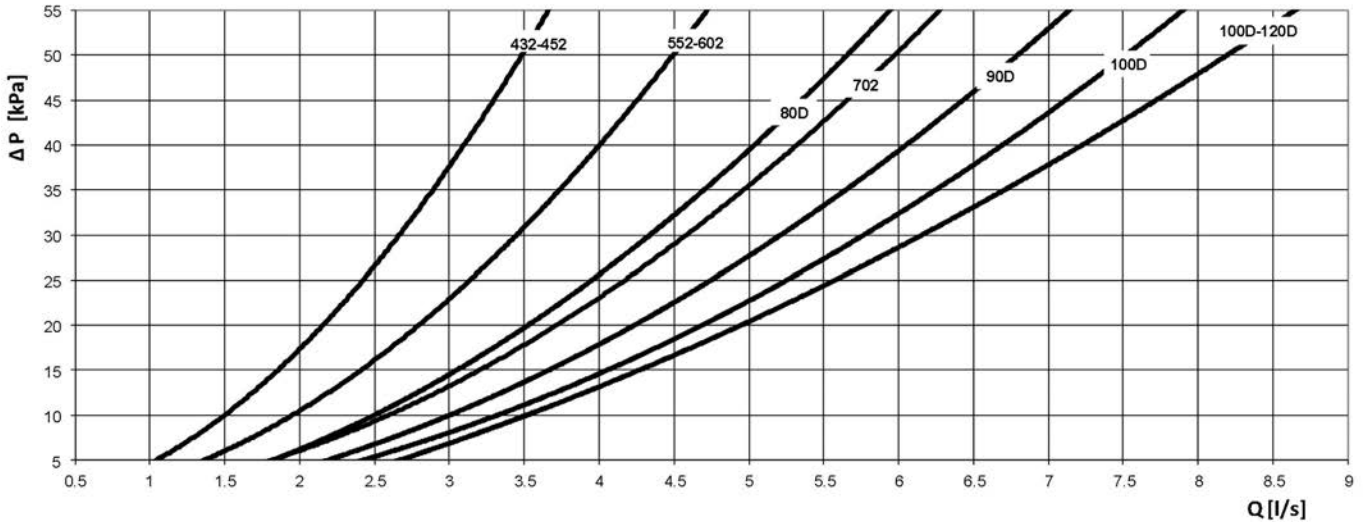

Q = water flow rate [l/s]
 DP = water side pressure drops (kPa)

R - Total energy recovery

A configuration which enables the production of hot water free-of-charge while operating in the cooling mode, thanks to the total recovery of condensation heat that would otherwise be disposed of into the external heat source. This solution increases the overall efficiency of the system in all cases where a high-level of hot water production is required. It is made up of a brazed plate heat exchanger made of 316 stainless steel, suitable for recovering all the unit heat capacity (equal to the sum of the cooling capacity and the electrical input capacity of the compressors), from the on-off type solenoid valve, from the supply and return temperature sensors in the hot water circuit and the related two-step integrated control logic.

Hot water availability is always subordinate to the production of chilled water.

See the following example:

- cooling capacity request = 100% / Heating capacity request = 0% > Production only of cooling capacity;
- cooling capacity request = 100% / Heating capacity request = 0% > Production of cooling and heating capacity by recovery;
- cooling capacity request = 50% / Heating capacity request = 100% > Production of cooling and heating capacity by recovery, equal to the 50% of the requested heating capacity.



To prevent constant switching in the unit's refrigeration circuit, it is necessary to install a storage tank with an adequate capacity in the system's hot water circuit.



In the absence of hot water circulation in the recovery exchanger, the maximum inlet air temperature is reduced by approximately 2°C compared with the unit without "Total Energy Recovery" mode.



Check availability and compatibility of "R - Total energy recovery" with the other accessories in the "Option compatibility" table.

Operating total energy recovery

When hot water is requested, the condensing coil is deactivated. Condensation takes place wholly within the recovery circuit.

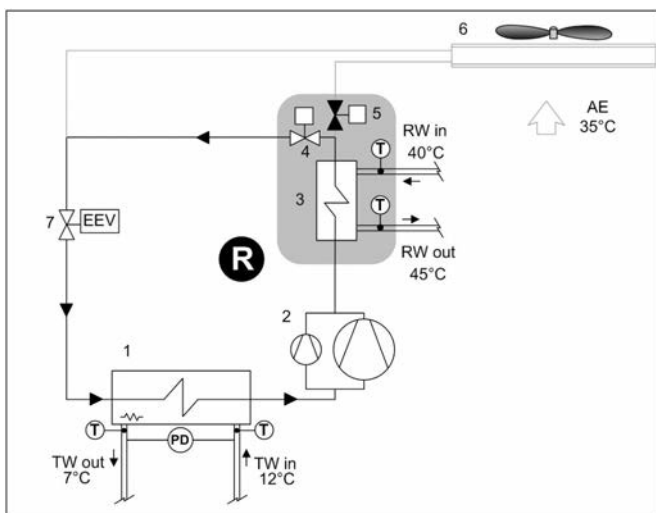

- R - Total recovery device
- 1 - Internal exchanger
- 2 - Compressors
- 3 - Recovery exchanger
- 4 - Total recovery enabling valve
- 5 - External exchanger enabling valve
- 6 - External exchanger
- 7 - Expansion electronic valve

T - Temperature probe
 TW in chilled water inlet
 TW out chilled water outlet

RW in - Recovery water input
 RW out - Recovery water output

PD - Differential pressure switch
 AE = Outdoor air intake

Not operating total energy recovery

When the recovery set-point has been satisfied, the condensing coil is reactivated. In this condition, the total recovery circuit operates as a Partial recovery circuit (Desuperheater).

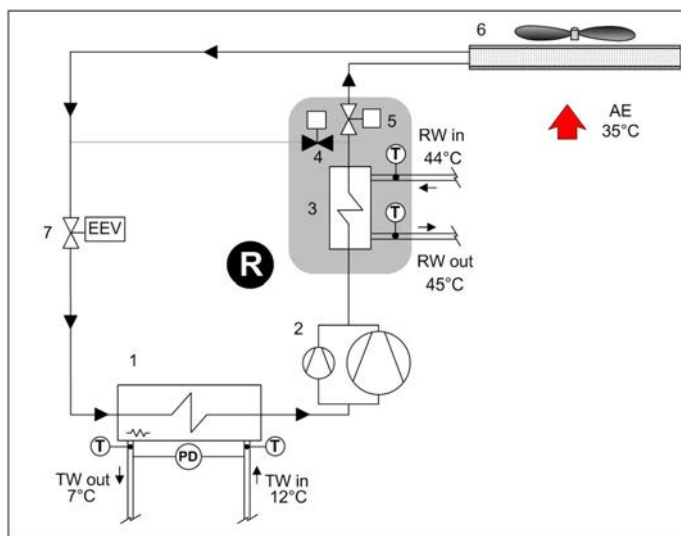

- R - Total recovery device
- 1 - Internal exchanger
- 2 - Compressors
- 3 - Recovery exchanger
- 4 - Total recovery enabling valve
- 5 - External exchanger enabling valve
- 6 - External exchanger
- 7 - Expansion electronic valve

T - Temperature probe
 TW in chilled water inlet
 TW out chilled water outlet

RW in - Recovery water input
 RW out - Recovery water output

PD - Differential pressure switch
 AE = Outdoor air intake

Pressure drops of the total energy recovery exchanger

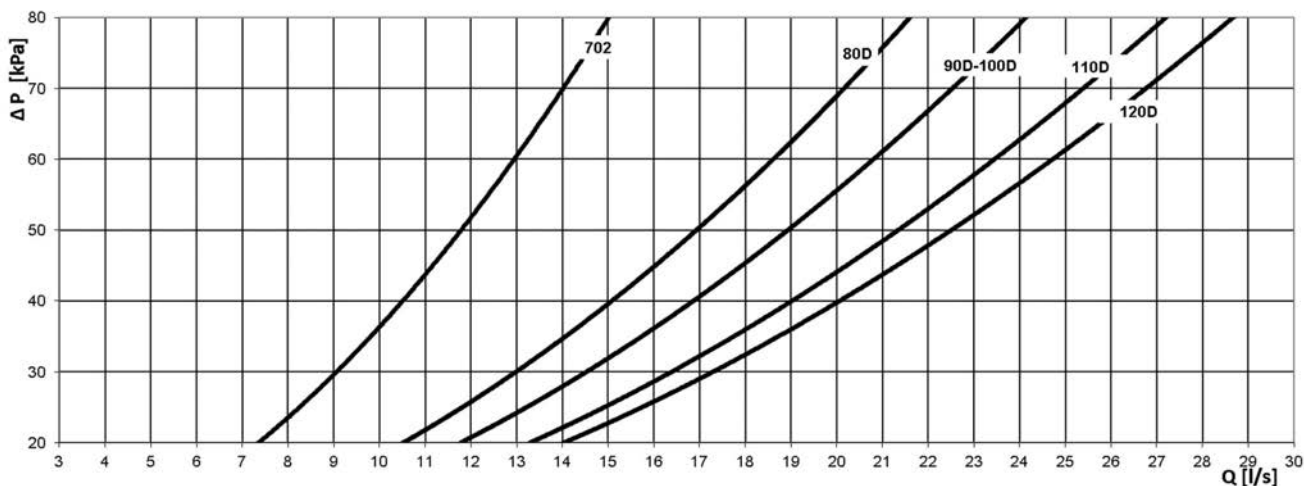

Q = water flow rate[l/s]
 DP = water side pressure drops (kPa)

Accessories - Hydronic assembly

ABU - Flush hydraulic connections

An option which simplifies the hydraulic connections which would otherwise be carried out within the unit (with the responsibility of the client).

Includes internal piping to the external unit panel, two quick connections flush to the unit, two outlet connections for the system connections which are to be soldered by the client.

The accessory is supplied installed built-in the unit.

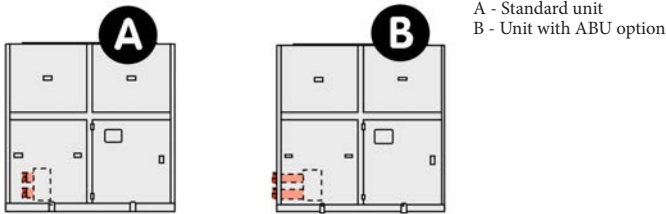

A - Standard unit
B - Unit with ABU option



The water connections flush with the unit are supplied as standard in units which are complete with at least one of the following options:

- Single pump
- HydroPack



It is also advisable to provide the system with the following components, which are excluded from the Clivet supplies:

- Cutoff valves, where not provided in the Clivet supply
- Piping support device and elastic vibration-proof joints
- Expansion tank (e.g. for closed circuit systems)
- Control thermometer on the supply
- Extra vent valves and discharge cocks where necessary

1PUS - Standard pump

Option supplied built-in the unit. Centrifugal electric pump with body and impeller made with AISI 304 or AISI 316 steel according to the models.

Three-phase electric motor with IP44-protection. Complete with thermoformed insulated casing, quick connections with insulated casing, non return valve, safety valve, pressure gauges, system load safety pressure switch, stainless steel antifreeze immersion heaters.

The various models which are available can be differentiated by the system available pressure.

STANDARD PUMP

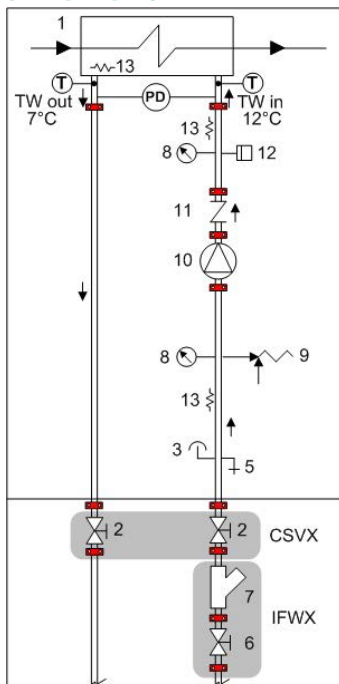

- 1 - Internal exchanger
- 2 - Cutoff valve
- 3 - Purge valve
- 5 - Draw off cock
- 6 - Cutoff valve with quick joints
- 7 - Steel mesh strainer water side
- 8 - Manometer
- 9 - Safety valve (6 Bar)
- 10 - Packaged electric pump with high efficiency impeller
- 11 - Non return valve
- 12 - System safety pressure switch (prevents the pumps from operating if no water is present)
- 13 - Electric heater

T - Temperature probe
PD - Differential pressure switch

TW in chilled water inlet
TW out chilled water outlet

The grey area indicates further optional components.

IFWX - steel mesh strainer water side
CSVX - Couple of manual shut-off valves

Performances of 1PUS options

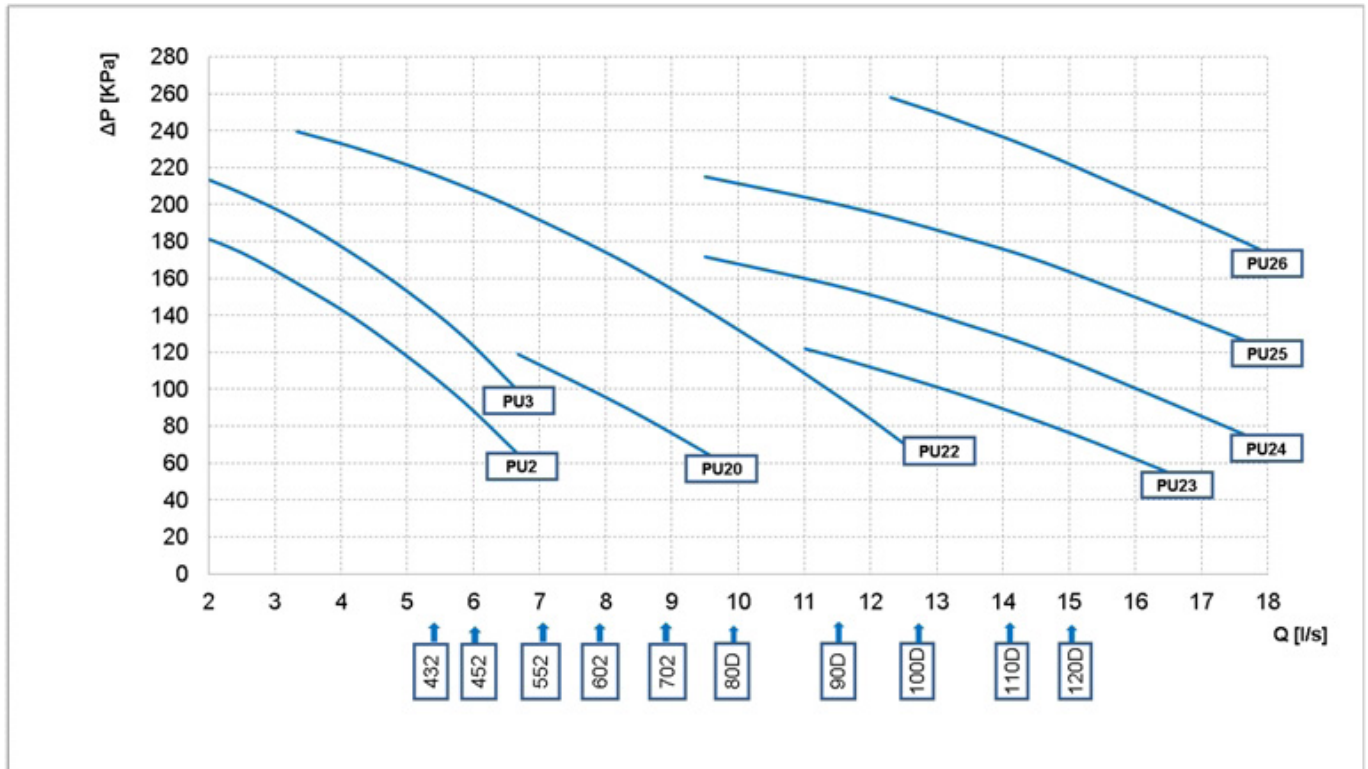

Q = water flow rate [l/s]
 DP [kPa] = Available pressure



Attention: in order to obtain the available pressure values, the heads represented in these diagrams must be lowered of the internal exchanger



Attention: in order to obtain the available pressure values, the heads represented in these diagrams must be lowered of the "IFWX - steel mesh strainer water side" accessory (where present)

Single Pump Technical Specifications

| Pump | Rated power [kW] | Nominal power [A] |
|------|------------------|-------------------|
| PU2 | 1,4 | 2,6 |
| PU3 | 1,8 | 3,2 |
| PU20 | 1,8 | 3,4 |
| PU22 | 3,3 | 5,6 |
| PU23 | 2,2 | 5 |
| PU24 | 3 | 6,2 |
| PU25 | 4 | 7,7 |
| PU26 | 5,5 | 10,4 |

CSVX - Couple of manual shut-off valves

It kit allows to isolate the hydraulic circuit at the inlet and outlet.

It includes:

- no. 2 cast-iron shut-off butterfly valves with fast fittings and activation lever with a mechanical calibration lock
- no. 2 of quick connections



Installation is the responsibility of the Client, externally to the unit.

Accessory separately supplied

IFWX - Steel mesh strainer water side

The device stops the exchanger from being clogged by any impurities which are in the hydraulic circuit. The mechanical steel mesh strainer must be placed on the water input line. It can be easily dismantled for periodical maintenance and cleaning. It also includes:

- cast-iron shut-off butterfly valve with quick connections and activation lever with a mechanical calibration lock;
- quick connections with insulated casing.

Steel mesh strainer pressure drops

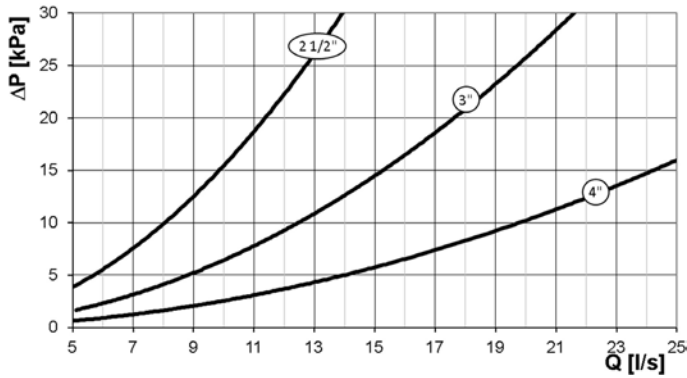

| EXCELLENCE | 432-702 | 80D-90D | 100D-120D |
|----------------------|---------|---------|-----------|
| Diameter | 2 1/2" | 3" | 4" |
| Degree of filtration | 1,6 mm | | |



Q = water flow rate [l/s]
 DP = water side pressure drops (kPa)

Note: the pressure drops are referred to the clean filter

- The device compulsorily requires the installation of the "CSVX - A COUPLE OF SHUT-OFF VALVES TO MANUAL OPERATION" accessory
- Installation is the responsibility of the Client, externally to the unit.
- Check for the presence of the required hydraulic shut-off valves in the system, in order to undertake periodical maintenance.
- We disclaim any liability and make the guarantee void, if an appropriate mechanical filter is not provided upstream of the system. Admitted filtration degree 1,6 mm

Accessory separately supplied

HydroPack

2 PM/3 PM - HydroPack with nr. 2/3 of pumps

Option supplied built-in the unit. Pumping unit made up of two or three electric pumps laid out in parallel, with auto-adaptive modular logic activation.

It enables the automatic reduction of the liquid flow rate in critical conditions, avoiding blocks due to overloading and consequential intervention work by specialised technical personnel.

Centrifugal electric pump with body and impeller made with AISI 304 or AISI 316 steel according to the models.

Three-phase electric motor with IP44-protection. Complete with thermoformed insulated casing, quick connections with insulated casing, non return valve, safety valve, pressure gauges, system load safety pressure switch, stainless steel antifreeze immersion heaters located at the return and supply point.

The various models which are available can be differentiated by the system available pressure.

The 2PM / 3PM option is supplied with a kit made up of 2 quick blind connections, for the removal of one pump in case of maintenance.

Provided with hydraulic interceptions to the outside of the unit (option 'CSVX - A pair of manually operated shut-off valves') to facilitate any major maintenance operations

HYDROPACK

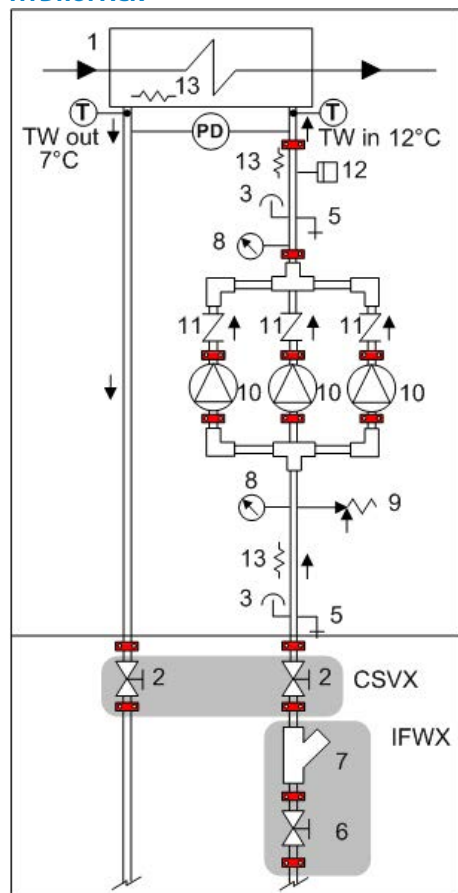

- 1 - Internal exchanger
- 2 - Cutoff valve
- 3 - Purge valve
- 5 - Draw off cock
- 6 - Cutoff valve with quick joints
- 7 - Steel mesh strainer water side
- 8 - Manometer
- 9 - Safety valve (6 Bar)
- 10 - Packaged electric pump with high efficiency impeller
- 11 - Non return valve
- 12 - System safety pressure switch (prevents the pumps from operating if no water is present)
- 13 - Electric heater

T - Temperature probe
PD - Differential pressure switch

TW in chilled water inlet
TW out chilled water outlet

The grey area indicates further optional components.

IFWX - steel mesh strainer water side
CSVX - Couple of manual shut-off valves

Performances of the 2 PM/3 PM option (HydroPack)

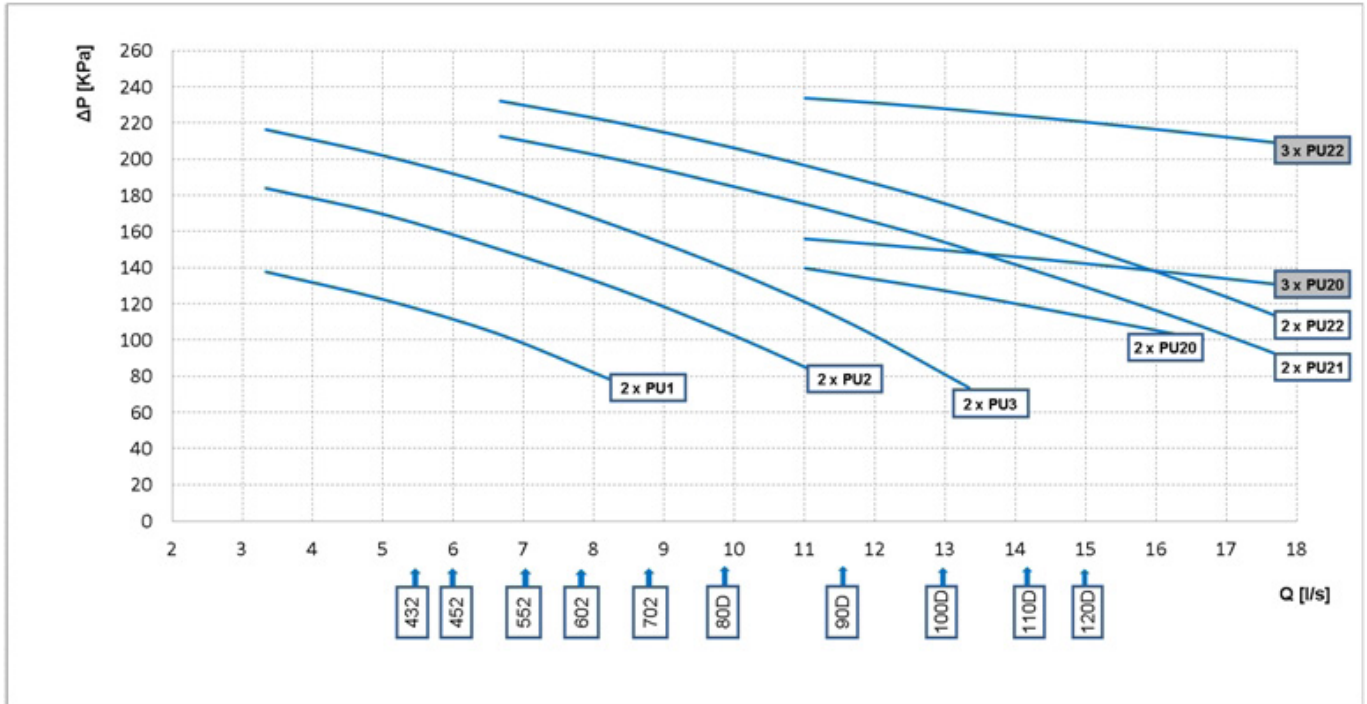

Q = water flow rate[l/s]
 DP [kPa] = Available pressure



Attention: in order to obtain the available pressure values, the heads represented in these diagrams must be lowered of the internal exchanger



Attention: in order to obtain the available pressure values, the heads represented in these diagrams must be lowered of the "IFWX - steel mesh strainer water side" accessory (where present)

Hydropack technical specifications

| PUMP | RATED FLOW [kW] | NOMINAL CURRENT [A] |
|----------|-----------------|---------------------|
| 2 x PU1 | 2 x 1,4 | 2 x 2,6 |
| 2 x PU2 | 2 x 1,4 | 2 x 2,6 |
| 2 x PU3 | 2 x 1,8 | 2 x 3,2 |
| 2 x PU20 | 2 x 1,8 | 2 x 3,4 |
| 2 x PU21 | 2 x 2,9 | 2 x 4,8 |
| 2 x PU22 | 2 x 3,3 | 2 x 5,6 |
| 3 x PU20 | 3 x 1,8 | 3 x 3,4 |
| 3 x PU22 | 3 x 3,3 | 3 x 5,6 |

Accessories

PGCT- Finned coil protection grilles and shaft

This accessory is used to protect the external coil from the accidental contact with external things or people. Ideal for installation in places where persons can pass from, such as car parks, terraces, etc. The accessory is provided and installed built-in the unit.

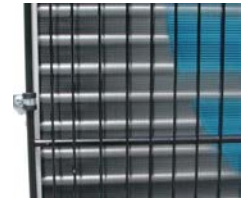

This option is not suitable for application in sulphuric environments.

CCCA - Copper / aluminium condensing coil with acrylic lining

Coils with copper pipes and aluminium fins with acrylic lacquering. Can be used in settings with moderately aggressive saline concentrations and other chemical agents.

Attention!

- Cooling capacity variation -2.7%
- variation in compressor power input +4.2%
- operating range reduction -2.1°C

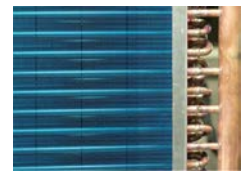

CCCA1 - Copper / aluminium condensing coils with Aluminium Energy Guard DCC treatment

A treatment which offers an optimal thermal exchange and guarantees and protects the finned coil exchangers from corrosion over time. Can be used in settings with very aggressive saline concentrations and other chemical agents in the air thus maintaining the performance of the coils over time.

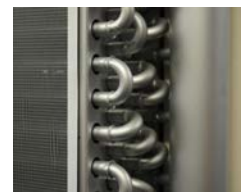

CCCC - Copper / copper condensing coil

Coils with copper pipes, copper fins and brass structure. Can be used in settings with moderately aggressive saline concentrations and other chemical agents.



This option is not suitable for application in sulphuric environments



Option available on request

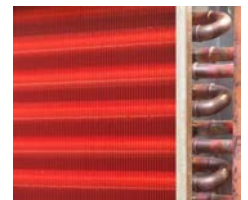

MHP - High and low pressure gauges

Although the standard unit already displays digital parameters of pressures in the refrigeration circuit, this option allows analog display of refrigerant pressures on suction and discharge lines for ease of use by maintenance technicians.

The two liquid pressure gauges and corresponding pressure sockets are installed on the machine in an easily accessible location.

The device is installed built-in the unit.



SDV - Cutoff valve on compressor supply and return

An option which integrates the supply cutoff valve, which is supplied as standard. The presence of the cock at the intake as well enables the compressors to be isolated and substituted without discharging the refrigerant from within the refrigeration circuit. This means that the extraordinary maintenance activities are facilitated.

The device is installed built-in the unit.

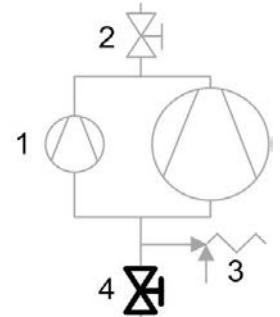

- 1. Compressors
- 2. Cutoff valve
- 3. Safety valve
- 4. SDV option

FANQE - Electrical panel ventilation

This option is necessary for very hot climates, where the outdoor temperature can be between +40°C and +50°C. It is made up of a system of forced ventilation, activated by a thermostat, which provides for the correct operating temperature to be maintained for the components inside the electrical panel. This option includes a thermostat which activates forced ventilation when necessary.

The device is installed and wired built-in the unit.



This accessory operates even when the unit is switched off provided that the power supply is maintained active and the unit continues to be connected.



The device operates only with powered units and not switched units. Be careful that you do not exceed a temperature of 50 °C inside the electrical panel during storage or on the installed unpowered unit.

MF2 - Multifunction phase monitor

The phase monitor controls the electrical parameters of the power line to the unit. It works on the command circuit and orders the unit to be switched off when one of the following cases is present: when the phase connections do not respect the correct sequence, or when there is over voltage or under voltage for a certain amount of time (limit values of over and under voltage and the time interval can be manually and separately set). When the line conditions are re-established, the unit is re-armed automatically.

The device is installed and wired built-in the unit.



The device prevents sudden changes of voltage; however, the voltage must always be in a range between 380V and 480V.

PFCP - Power-factor capacitors

The component is necessary to lower the phase difference between current and voltage in the electromagnetic components of the unit (e.g. asynchronous motors). The component allows to put the cosφ power factor to values on average higher than 0.9, reducing the network reactive power. This often leads to an economic benefit which the energy provider grants to the final user.

The device is installed and wired built-in the unit.



ECS - ECOSHARE function for the automatic management of a group of units

The device allows automatic management of units that operate on the same hydraulic circuit, by creating a local communication network.

There are two control modes that can be set via a parameter during the activation stage. They both distribute the heat load on the available units by following the distribution logic to benefit from efficiency levels at part load.

Moreover:

Mode 1 - it keeps all the pumps active

Mode 2 - it activates only the pumps of the unit required to operate

The device allows for rotation based on the criterion of minimum wear and management of units in stand-by. There are various unit sizes. Every unit must be fitted with the ECOSHARE feature. The set of units is controlled by a Master unit.

The local network can be extended up to 7 units (1 Master and 6 Slave).



The unit supplied with this device can also be equipped at the same time with the RCMRX option and one of the CMSC8 / CMSC9 / CMSC10 options.

SFSTR – Starting current reduction device

This option is also known as “Soft starter”. An electronic device which automatically starts up the compressors gradually, reducing the starting current for the unit by around 40% in comparison with the nominal value.

This results in the electrical capacity system and the related protection devices being sized with lower parameters, thus having a lower initial investment cost.

The device is installed and wired built-in the unit.

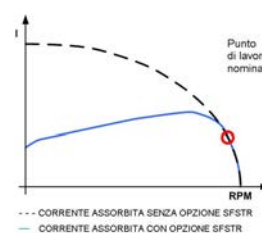

-- Absorbed current without SFSTR option
 - Absorbed current with SFSTR option

CMSC8 - Serial communication module for BACnet supervisor

This enables the serial connection of the supervision system, using BACnet as the communication protocol. It enables access to the complete list of operational variables, commands and alarms. Using this accessory every unit can dialogue with the main supervision systems.

The device is installed and wired built-in the unit.



The configuration and management activities for the BACnet networks are the responsibility of the client.



The total length of each serial line do not exceed 1000 meters and the line must be connected in bus typology (in/out)



CMSC9 - Serial communication module for Modbus supervisor

This enables the serial connection of the supervision system, using Modbus as the communication protocol. It enables access to the complete list of operational variables, commands and alarms. Using this accessory every unit can dialogue with the main supervision systems.

The device is installed and wired built-in the unit.



The total length of each serial line do not exceed 1000 meters and the line must be connected in bus typology (in/out)



CMSC10 - Serial communication module for LonWorks supervisor

This enables the serial connection of the supervision system which uses the LonWorks communication protocol. It enables access to a list of operating variables, commands and alarms which comply with the Echelon® standard.

The device is installed and wired built-in the unit.



The configuration and management activities for the LonWorks networks are the responsibility of the client.



LonWorks technology uses the LonTalk® protocol for communicating between the network nodes. Contact the service supplier for further information.



The total length of each serial line do not exceed 1000 meters and the line must be connected in bus typology (in/out)



CONTA2 - Energy meter

Allows to display and record the unit's main electrical parameters. The data can be displayed with the user interface on the unit or via the supervisor through the specific protocol variables.

It is possible to control:

- voltage (V),
- absorbed current (A),
- frequency (Hz),
- cosφ,
- power input (KW),
- absorbed energy (KWh),
- harmonic components (%).

The device is installed and wired built-in the unit.



Only the following parameters are available on the LonWorks protocol: absorbed power (kW) and absorbed energy (kWh)



SPC4 - Set-point compensation with 0-10 V signal

This device enables the set-point to be varied which is pre-set using an external 0÷10 V signal.

The device is installed and wired built-in the unit.

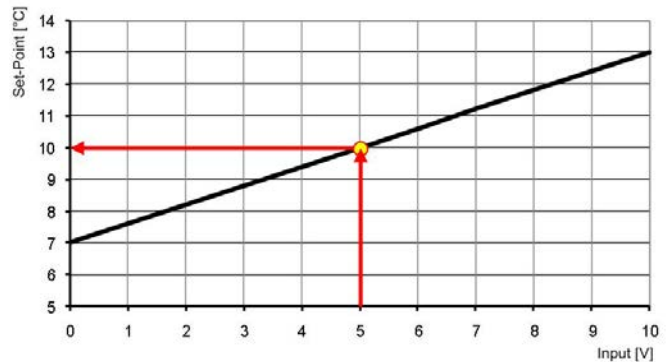

SPC2 - Set-point compensation with outdoor air temperature probe

This device enables the set-point to be varied automatically which is pre-set depending on the outdoor air temperature. This device enables the liquid flow temperature to be obtained, which varies depending on external conditions, enabling energy savings throughout the entire system.

The device is installed and wired built-in the unit.



Accessories separately supplied

RCMRX - Remote control via microprocessor remote control

This option allows to have full control over all the unit functions from a remote position.

It can be easily installed on the wall and has the same aspect and functions of the user interface on the unit.

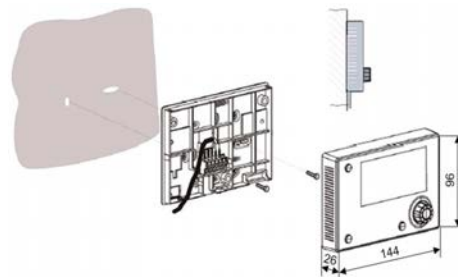

All device functions can be repeated with a normal portable PC connected to the unit with an Ethernet cable and equipped with an internet navigation browser.



The device must be installed on the wall with suitable plugs and connected to the unit (installation and wiring to be conducted by the Customer). Maximum remote control distance 350 m without auxiliary power supply. For distances greater than 350 m and in any case less than 700 m it is necessary to install the 'PSX - Mains power unit' accessory.



Data and power supply serial connection cable n.1 twisted and shielded pair. Diameter of the individual conductor 0.8 mm.

PSX - Mains power supply unit

The device allows the unit and the remote control to communicate with the user interface even when the serial line is longer than 350m.

It must be connected to the serial line at a distance of 350m from the unit and allows to extend the length to 700m maximum in total. The device requires an external power supply at 230V AC.



Power supply at 230V AC provided by Customer



AMMX - Spring antivibration mounts

The spring antivibration mounts are attached in special housing on the support frame and serve to smooth the vibrations produced by the unit thus reducing the noise transmitted to the support structure.



Option compatibility - WSA-XSC2 series

| REFERENCE | DESCRIPTION | 432 | 452 | 552 | 602 | 702 | 80D | 90D | 100D | 110D | 120D |
|--|-------------------------------------|-----|-----|-----|-----|-----|-----|-----|------|------|------|
| CONFIGURATIONS AND MAIN ACCESSORIES | | | | | | | | | | | |
| B | Water low temperature | 0 | 0 | 0 | 0 | 0 | 0 | 0 | 0 | 0 | 0 |
| D | Partial energy recovery | 0 | 0 | 0 | 0 | 0 | 0 | 0 | 0 | 0 | 0 |
| R | Total energy recovery | X | X | X | X | 0 | 0 | 0 | 0 | 0 | 0 |
| 1PUS - STANDARD PUMP | | | | | | | | | | | |
| PU2 | Type 2 pump | 0 | 0 | X | X | X | X | X | X | X | X |
| PU3 | Type 3 pump | 0 | 0 | X | X | X | X | X | X | X | X |
| PU20 | Pump 20 | X | X | 0 | 0 | 0 | X | X | X | X | X |
| PU22 | Pump 22 | 0 | 0 | 0 | 0 | 0 | 0 | 0 | X | X | X |
| PU23 | Pump 23 | X | X | X | X | X | X | 0 | 0 | 0 | 0 |
| PU24 | Pump 24 | X | X | X | X | X | 0 | 0 | 0 | 0 | 0 |
| PU25 | Pump 25 | X | X | X | X | X | 0 | 0 | 0 | 0 | 0 |
| PU26 | Pump 26 | X | X | X | X | X | X | X | 0 | 0 | 0 |
| PU2 + R | Pump type 2 + Total energy recovery | 0 | 0 | X | X | X | X | X | X | X | X |
| PU3 + R | Pump type 3 + Total energy recovery | 0 | 0 | X | X | X | X | X | X | X | X |
| PU20 + R | Pump 20 + Total energy recovery | X | X | 0 | 0 | X | X | X | X | X | X |
| PU22 + R | Pump 22 + Total energy recovery | 0 | 0 | 0 | 0 | X | X | 0 | 0 | 0 | 0 |
| PU23 + R | Pump 23 + Total energy recovery | X | X | X | X | X | X | 0 | 0 | 0 | 0 |
| PU24 + R | Pump 24 + Total energy recovery | X | X | X | X | X | X | 0 | 0 | 0 | 0 |
| PU25 + R | Pump 25 + Total energy recovery | X | X | X | X | X | X | 0 | 0 | 0 | 0 |
| PU26 + R | Pump 26 + Total energy recovery | X | X | X | X | X | X | X | 0 | 0 | 0 |
| 2PM - HYDROPACK WITH NO.2 PUMPS | | | | | | | | | | | |
| PU1 | Type 1 pump | 0 | 0 | 0 | 0 | X | X | X | X | X | X |
| PU2 | Type 2 pump | 0 | 0 | 0 | 0 | 0 | 0 | X | X | X | X |
| PU3 | Type 3 pump | 0 | 0 | 0 | 0 | 0 | 0 | 0 | 0 | X | X |
| PU20 | Pump 20 | X | X | X | X | X | X | 0 | 0 | 0 | 0 |
| PU21 | Pump 21 | X | X | 0 | 0 | 0 | 0 | 0 | 0 | 0 | 0 |
| PU22 | Pump 22 | X | X | 0 | 0 | 0 | 0 | 0 | 0 | 0 | 0 |
| PU1 + R | Pump type 1 + Total energy recovery | 0 | 0 | 0 | 0 | X | X | X | X | X | X |
| PU2 + R | Pump type 2 + Total energy recovery | 0 | 0 | 0 | 0 | X | X | X | X | X | X |
| PU3 + R | Pump type 3 + Total energy recovery | 0 | 0 | 0 | 0 | X | X | X | X | X | X |
| PU20 + R | Pump 20 + Total energy recovery | X | X | X | X | X | X | X | X | X | X |
| PU21 + R | Pump 21 + Total energy recovery | X | X | 0 | 0 | X | X | X | X | X | X |
| PU22 + R | Pump 22 + Total energy recovery | X | X | 0 | 0 | X | X | X | X | X | X |
| 3PM - HYDROPACK WITH NO.3 PUMPS | | | | | | | | | | | |
| PU20 | Pump 20 | X | X | X | X | X | X | 0 | 0 | 0 | 0 |
| PU22 | Pump 22 | X | X | X | X | X | X | 0 | 0 | 0 | 0 |
| PU20 + R | Pump 20 + Total energy recovery | X | X | X | X | X | X | X | X | X | X |
| PU22 + R | Pump 22 + Total energy recovery | X | X | X | X | X | X | X | X | X | X |

o Option

× Not available

Dimensional drawings

WSA-XSC2 432-602

DAA1Z432_602_0

Date: 14/02/2013

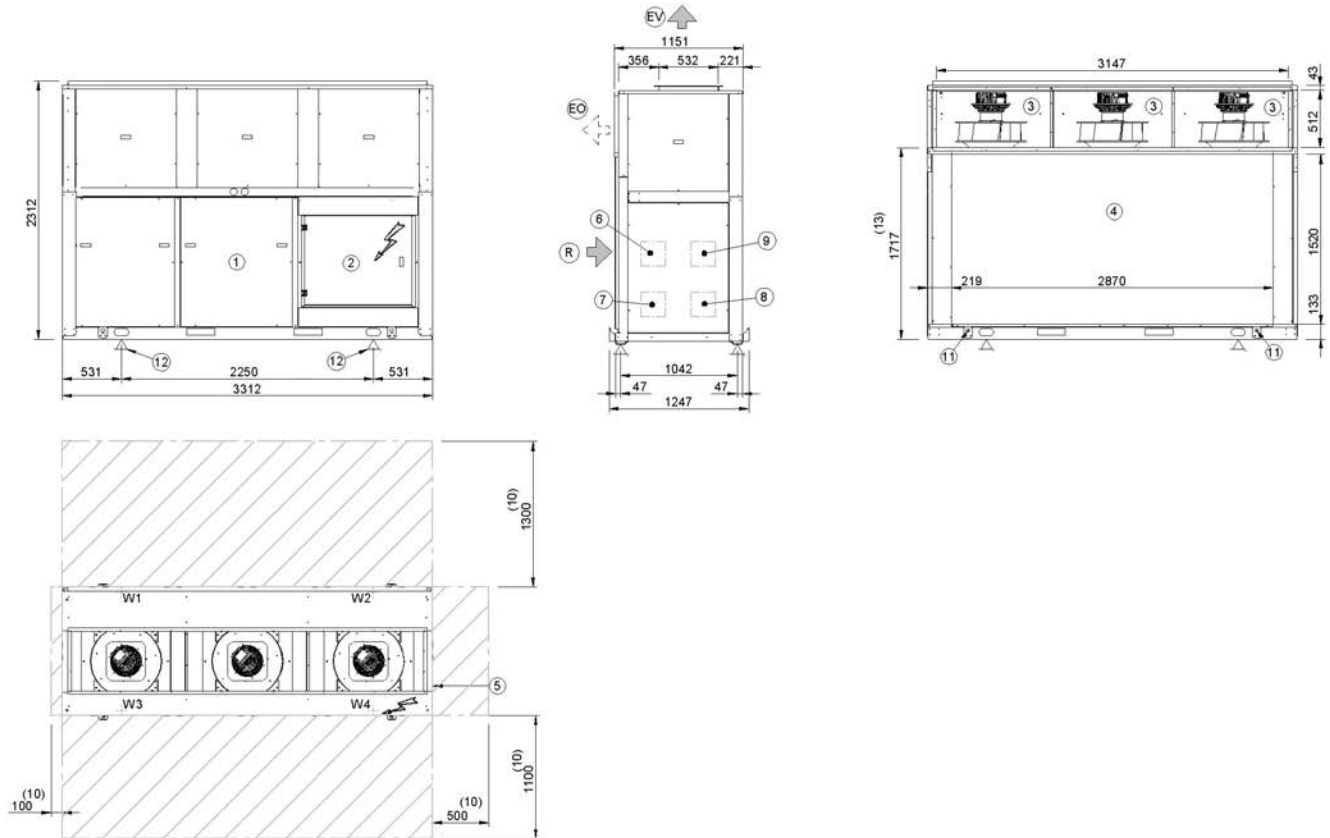

- (1) Compressor compartment
- (2) General electrical panel
- (3) Exhaust radial electric fans
- (4) External exchanger
- (5) Power line input
- (6) internal exchanger water inlet (victaulic) standard unit or with pump option
- (7) internal exchanger water outlet (victaulic) standard unit or with pump option
- (8) Recovery side exchanger water inlet (optional)

- Position of the connections in relation with the recovery
- (9) Recovery side exchanger water outlet (optional)
- Position of the connections in relation with the recovery
- (10) Functional clearances
- (11) Lifting brackets (removable)
- (12) Fixing points
- (13) Unit height without fan section
- (R) Outdoor air return
- (EV) Vertical air exhaust (Standard)
- (EO) Horizontal air exhaust (OPTIONAL)

| Size | | 432 | 452 | 552 | 602 |
|--------------------------------------|----|------|------|------|------|
| A - Length | mm | 3312 | 3312 | 3312 | 3312 |
| B - Width | mm | 1151 | 1151 | 1151 | 1151 |
| C - Height | mm | 2312 | 2312 | 2312 | 2312 |
| W1 Supporting Point | kg | 332 | 329 | 354 | 380 |
| W2 Supporting Point | kg | 304 | 300 | 320 | 338 |
| W3 Supporting Point | kg | 374 | 349 | 396 | 411 |
| W4 Supporting Point | kg | 420 | 406 | 437 | 444 |
| W5 Supporting Point | kg | 0.0 | 0.0 | 0.0 | 0.0 |
| W6 Supporting Point | kg | 0.0 | 0.0 | 0.0 | 0.0 |
| Shipping weight | kg | 1408 | 1359 | 1482 | 1545 |
| Operating weight | kg | 1430 | 1384 | 1507 | 1573 |
| Internal exchanger water connections | Ø | 2 ½" | 2 ½" | 2 ½" | 2 ½" |
| Partial recovery water connections | Ø | 1 ¼" | 1 ¼" | 1 ¼" | 1 ¼" |
| Total recovery water connections | Ø | 2" | 2" | 2" | 2" |

The presence of optional accessories may result in a substantial variation of the weights shown in the table.

WSA-XSC2 702-80D

DAA1Z702_80D_0

Date: 14/02/2013

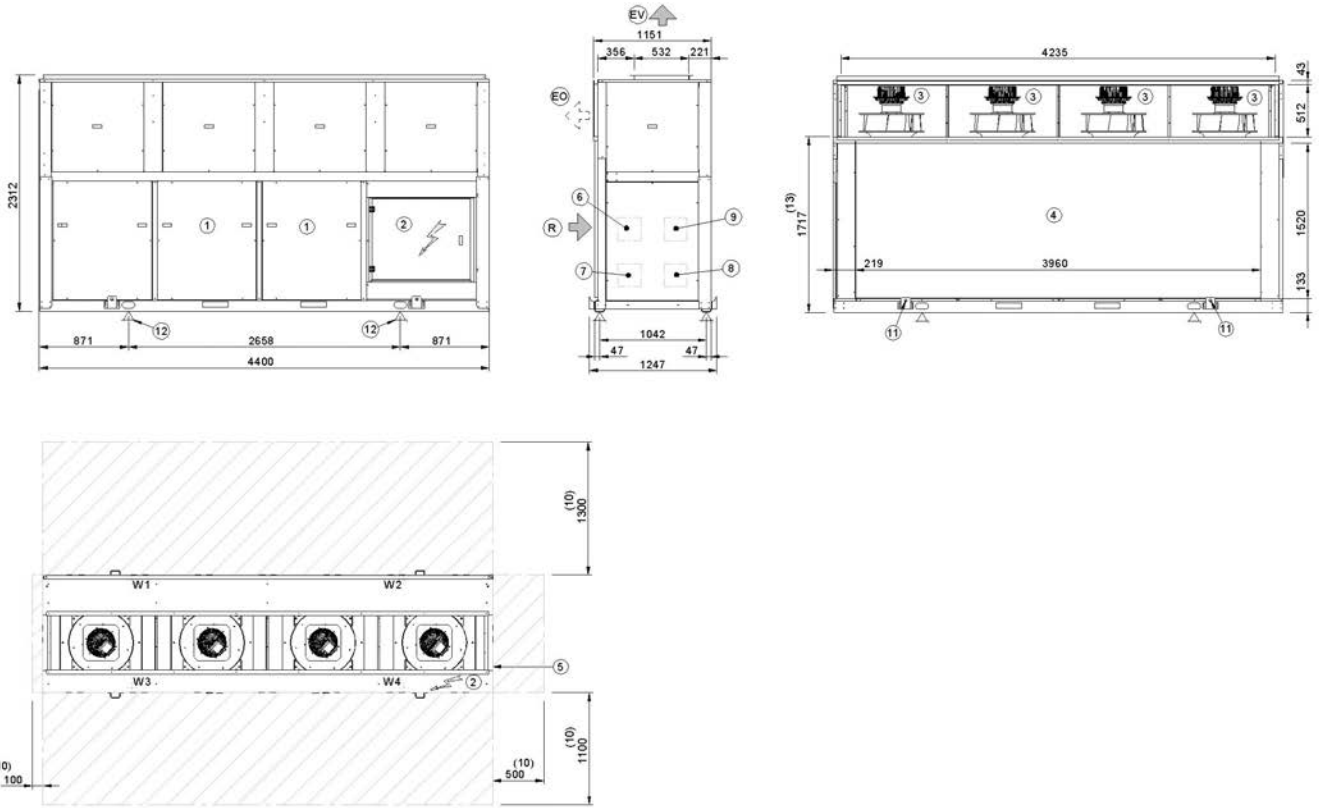

- (1) Compressor compartment
- (2) General electrical panel
- (3) Exhaust radial electric fans
- (4) External exchanger
- (5) Power line input
- (6) Internal exchanger water inlet (victaulic) standard unit or with pump option
- (7) Internal exchanger water outlet (victaulic) standard unit or with pump option
- (8) Recovery side exchanger water inlet (optional)

- (9) Recovery side exchanger water outlet (optional)
- (10) Functional clearances
- (11) Lifting brackets (removable)
- (12) Fixing points
- (13) Unit height without fan section
- (R) Outdoor air return
- (EV) Vertical air exhaust (Standard)
- (EO) Horizontal air exhaust (OPTIONAL)

| Size | | 702 | 80D |
|--------------------------------------|----|------|------|
| A - Length | mm | 4400 | 4400 |
| B - Width | mm | 1151 | 1151 |
| C - Height | mm | 2312 | 2312 |
| W1 Supporting Point | kg | 425 | 449 |
| W2 Supporting Point | kg | 434 | 443 |
| W3 Supporting Point | kg | 403 | 484 |
| W4 Supporting Point | kg | 599 | 618 |
| W5 Supporting Point | kg | 0.0 | 0.0 |
| W6 Supporting Point | kg | 0.0 | 0.0 |
| Shipping weight | kg | 1831 | 1967 |
| Operating weight | kg | 1861 | 1994 |
| Internal exchanger water connections | ∅ | 2½" | 3" |
| Partial recovery water connections | ∅ | 2" | 2" |
| Total recovery water connections | ∅ | 3" | 3" |

The presence of optional accessories may result in a substantial variation of the weights shown in the table.

WSA-XSC2 90D-120D

DAA1Z90D_120D_0

Date: 14/02/2013

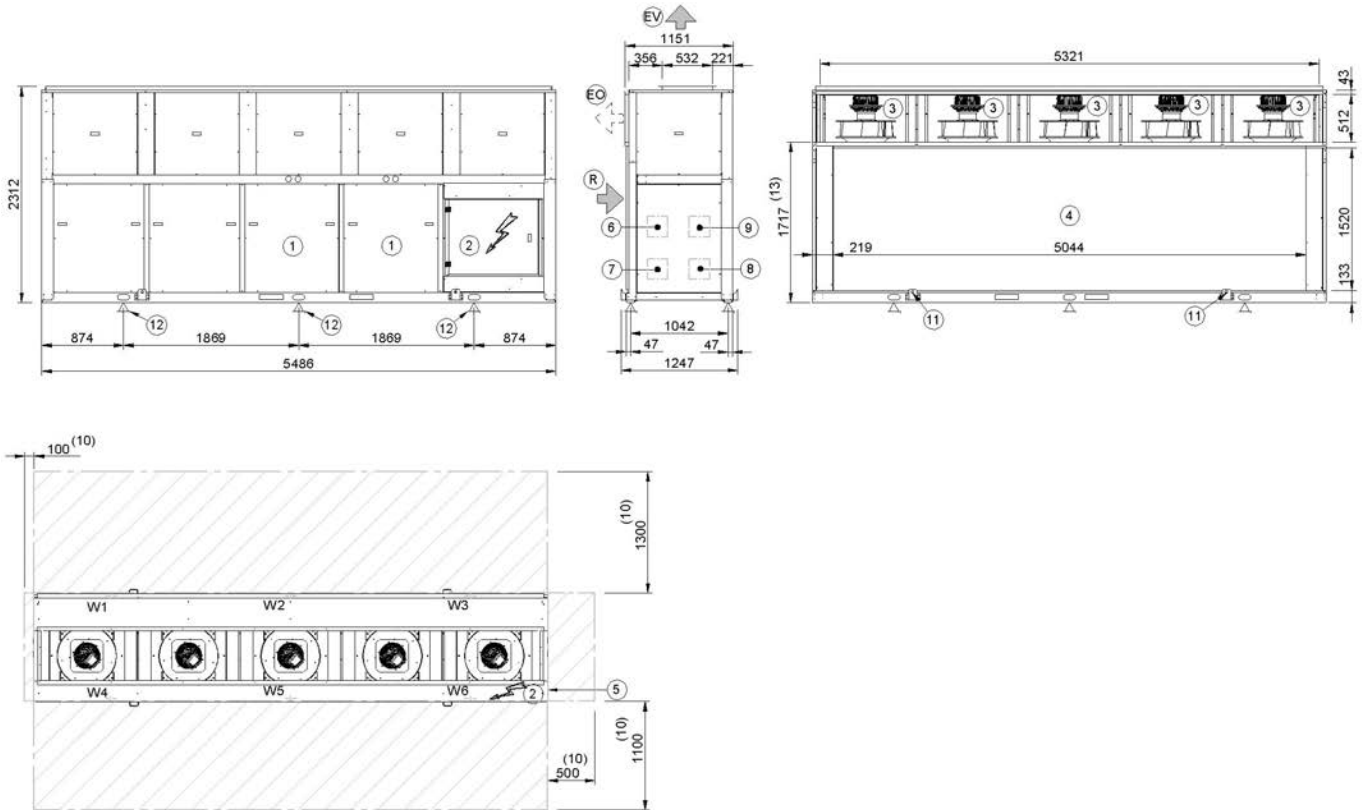

- (1) Compressor compartment
- (2) General electrical panel
- (3) Exhaust radial electric fans
- (4) External exchanger
- (5) Power line input
- (6) internal exchanger water inlet (victaulic) standard unit or with pump option
- (7) internal exchanger water outlet (victaulic) standard unit or with pump option
- (8) Recovery side exchanger water inlet (optional)

- (9) Recovery side exchanger water outlet (optional)
- (10) Functional clearances
- (11) Lifting brackets (removable)
- (12) Fixing points
- (13) Unit height without fan section
- (R) Outdoor air return
- (EV) Vertical air exhaust (Standard)
- (EO) Horizontal air exhaust (OPTIONAL)

| Size | | 90D | 100D | 110D | 120D |
|--------------------------------------|----|------|------|------|------|
| A - Length | mm | 5486 | 5486 | 5486 | 5486 |
| B - Width | mm | 1151 | 1151 | 1151 | 1151 |
| C - Height | mm | 2312 | 2312 | 2312 | 2312 |
| W1 Supporting Point | kg | 267 | 270 | 290 | 290 |
| W2 Supporting Point | kg | 522 | 574 | 621 | 630 |
| W3 Supporting Point | kg | 298 | 302 | 321 | 322 |
| W4 Supporting Point | kg | 187 | 185 | 186 | 185 |
| W5 Supporting Point | kg | 714 | 830 | 872 | 900 |
| W6 Supporting Point | kg | 381 | 400 | 405 | 410 |
| Shipping weight | kg | 2331 | 2513 | 2642 | 2684 |
| Operating weight | kg | 2369 | 2561 | 2695 | 2737 |
| Internal exchanger water connections | Ø | 3" | 4" | 4" | 4" |
| Partial recovery water connections | Ø | 2" | 2" | 2" | 2" |
| Total recovery water connections | Ø | 3" | 3" | 3" | 3" |

The presence of optional accessories may result in a substantial variation of the weights shown in the table.

**CLIVET SPA**

Via Camp Lonc 25, Z.I. Villapaiera - 32032 Feltre (BL) - Italy
Tel. + 39 0439 3131 - Fax + 39 0439 313300 - info@clivet.it

CLIVET ESPAÑA S.A.

Parque Empresarial Villapark, Avda. Quitapesares 50 - 28670, Villaviciosa de Odón, Madrid - España
Tel. + 34 91 6658280 - Fax + 34 91 6657806 - info@clivet.es

CLIVET UK LTD

4 Kingdom Close, Segensworth East - Fareham, Hampshire - PO15 5TJ - United Kingdom
Tel. + 44 (0) 1489 572238 - Fax + 44 (0) 1489 573033 - info@clivet-uk.co.uk

CLIVET NEDERLAND B.V.

Siliciumweg 20a, 3812 SX Amersfoort - Netherlands
Tel. + 31 (0) 33 7503420 - Fax + 31 (0) 33 7503424 - info@clivet.nl

CLIVET GmbH

Hummelsbütteler Steindamm 84, 22851 Norderstedt - Germany
Tel. + 49 (0) 40 32 59 57-0 - Fax + 49 (0) 40 32 59 57-194 - info.de@clivet.com

CLIVET RUSSIA

Elektrozavodskaya st. 24, office 509 - 107023, Moscow, Russia
Tel. + 74956462009 - Fax + 74956462009 - info.ru@clivet.com

CLIVET MIDEAST FZCO

Dubai Silicon Oasis (DSO), High Bay Complex, Ind Unit No. 3, PO BOX 28178, Dubai, UAE
Tel. + 9714 3208499 - Fax + 9714 3208216 - info@clivet.ae

CLIVET AIRCONDITIONING SYSTEMS (P) LTD

3C3, Gundecha Onclave - Kherani Road, Saki Naka, Andheri (East) - Mumbai 400 072 - India
Tel. + 91 22 6193 7000 - Fax + 91 22 6193 7001 - sales.india@clivet.com